

RESILIENT SEATED GATE VALVE RISING STEM WITH FLANGES and IPS GROOVE

Table 1

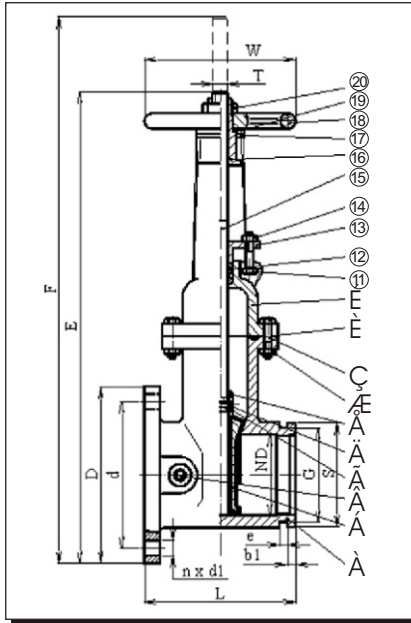

No.	Description	Material
20	Wheel Lock Nut	ASTM B16
19	Yoke Lock Nut	ASTM B16
18	Handwheel	ASTM A126 cl. B
17	Washer for DN 6"	ASTM B62
16	Yoke Sleeve	ASTM B62
15	Stem	ASTM B16
14	Hex Nut	ASTM B16
13	Follower	ASTM A126 cl. B
12	Packing	sq Braited PTFE + graphite
11	Hex. Hd. Bolt	ASTM A307 gr. B - zinc coated
10	Bonnet	ASTM A126 cl. B
9	Gasket	Rubber NBR
8	Hex. Hd. Bolt	ASTM A307 gr. B - zinc coated
7	Hex Nut	ASTM A307 gr. B - zinc coated
6	"O" Ring	Rubber NBR
5	Wedge Pin	AISI 304
4	Wedge Nut	ASTM B16
3	Plug	AISI 304
2	Wedge	ASTM A126 cl. B+NBR Coated
1	Body	ASTM A126 cl. B

Fig. 1

Class	Size	Dimensions							
		inch mm	2 1/2" 65	3" 80	4" 100	6" 150	8" 200	10" 254	
200	L	±1.06	inch	7 1/2	8	9	10 1/2	11 1/2	13
		±1.6	mm	190.5	203.2	228.5	266.5	292.1	330.2
	D	±0.06	inch	7	7 1/2	9	11	13 1/2	16
		±1.6	mm	177.8	190.5	228.5	279.5	342.9	406.4
	W		inch	7 1/2	10	10	12	14	16
			mm	190.5	254	254	304.8	355.6	406.4
	*E		inch	13 7/8	15 5/8	18 1/4	23 1/4	29 1/4	35 3/8
			mm	352	397	464	603	743	899
	*F		inch	16 3/8	18 7/8	22 3/4	30 1/8	37 1/4	45 3/4
			mm	416	479	578	765	959	1162
	d	±0.06	inch	5 1/2	6	7 1/2	9 1/2	11.75	14.25
		±1.6	mm	139.7	152.4	190.5	241.3	298.5	361.9
	n x dl	±0.03	inch	4 x 0.75	4x0.75	8x0.75	8x0.88	8x0.88	12x1.0
		±0.8	mm	4 x 19	4x19	8x19	8x22	8x22	12x25.4
	b	+0.12 0	inch	11/16	3/4	15/16	1	1 1/8	1 3/8
		+3 0	mm	17.5	19	23.8	25.4	28.5	30
	G	±0.02	inch	2.710	3.334	4.334	6.445	8.431	10.552
		±0.5	mm	68.8	84.7	110.1	163.7	214.1	268
	S	±0.03	inch	2.875	3.5	4.5	6.625	8.625	10.750
		±0.8	mm	73	88.9	114.3	168.3	219.1	273
bl	±0.03	inch	0.625	0.625	0.625	0.625	0.75	0.175	
	±0.8	mm	15.8	15.8	15.8	15.8	19	19	
e	±0,03	inch	0.312	0.312	0.375	0.375	0.438	0.500	
	±0.8	mm	7.9	7.9	9.5	9.5	11.1	12.7	
T		inch	0.75	1	1	1.125	1.25	1.375	
		mm	19.1	25.4	25.4	28.5	31.8	34.9	
Plug	No/inch	1 1/2"-14NPT 2 3/4"-14NPT	3 3/4"-14 NPT	3 3/4"-14 NPT	3 3/4"-14 NPT	3 3/4"-14 NPT	3 3/4"-14 NPT	3 3/4"-14 NPT	
*Weight		lbs	50	62	90	132	132	364	
		kg	22.5	28	41	60	105	165	

Table 2

* Approximated values;