



ABO valve

ABsOlute flow control



SERIES 3E

// DN 150 - 400 (6" - 16")

// Oil & Gas

// Power Generation

// Petrochemistry

CE

TRIPLE OFFSET BUTTERFLY VALVES

WWW.ABOVALVE.COM

GENERAL INFORMATION

GENERAL CHARACTERISTICS

- Triple offset design
- Shut-off and regulating device
- Metal/Metal sealing
- High opening & closing performance
- Zero leakage (no visible leakage when tested at high pressure with water and low pressure with air according to current international standards)
- Easy repair & maintenance
- Easy installation & mounting

APPLICATIONS

High performance applications such as chilled water, water, utility lines, gasoline, natural gas, air, oil, jet fuels and process lines, such as:

- Oil Tankers
- Refineries
- Power Generation
- Oil & Gas
- Steel & Mining
- Pulp & Paper
- Chemical & Petrochemical Industry
- Food & Beverage

STANDARDS

LEAK TEST:

- EN 12266-1, Rate A/B*
- ISO 5208, Rate A/B*
- API 598, TAB. 5
- ANSI (FC) 70-2, Class VI

FACE TO FACE ACC.:

- EN 558, SERIES 20
- ISO 5752, SERIES 20
- API 609, TAB. 3

CONNECTION BETWEEN

- FLANGES:**
- EN 1092-1, 2
- DIN 2631 - 35
- ASME B16.5

ATEX OPTION:

- Version according to ATEX 94/9/EC
- Zone 1 and 21 – Gr II, Cat. 2 G

TOP FLANGE:

- EN ISO 5211

MARKING:

- EN19

WORKING STANDARD:

- EN 593 + A1

*For tightness rate A, please consult with the manufacturer.

TYPE DESIGNATION

3E-3 5 L 4 B 150

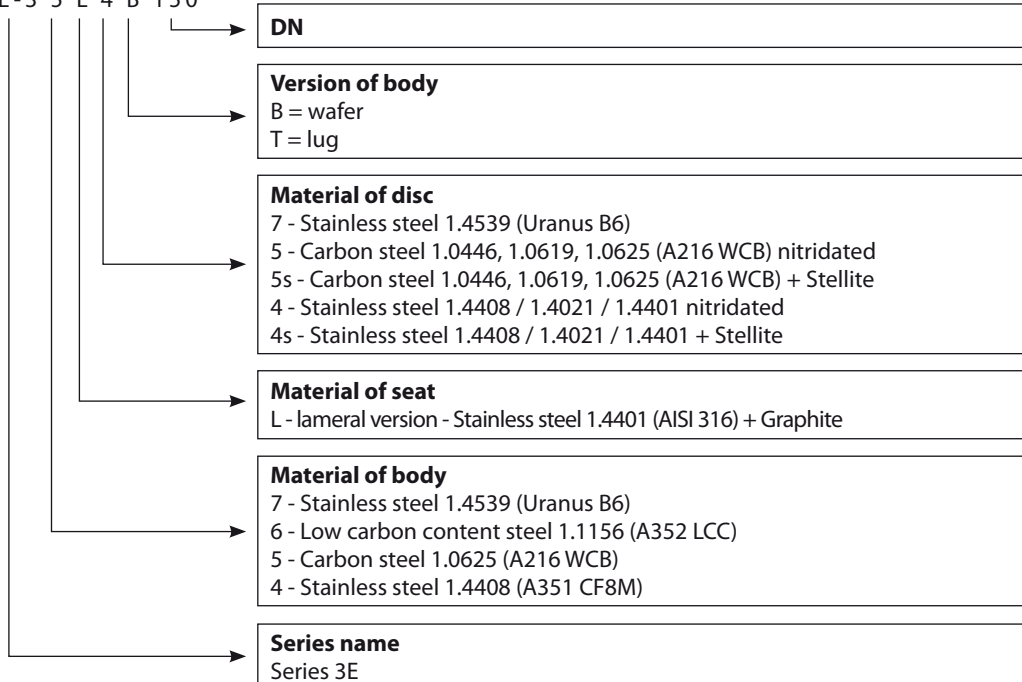

Models

Wafer type B Lug type T

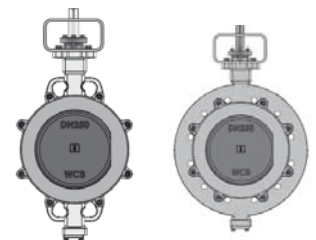

PRODUCT QUALITY AND CONTROL

ABO production facilities are certified in accordance to ISO 9001 quality system, which ensures product quality and precision in manufacturing as well as strict product testing. Quality control guidelines and procedures include number of steps in 3 main areas: Incoming materials control, In-production control and After-production control.

- Test procedures are established according to: EN 12266-1, ISO 5208, API 598, ANSI/FCI 70-2
- Manufacture according to the requirements of the European Directive 97/23/CE – Equipment under pressure (Category III, modul B)
- All ABO valves pass pressure tests to 110% of rated pressure to ensure bubble tight shutoff
- All actuators are calibrated and cycle tested before shipment
- Material Traceability Rule – Certification is provided for all supplied valves as per customer's request
- Positive Material Identification – All materials are subjected to PMI testing in order to verify Material Traceability Certificate

Certificates - Complete list of certificates can be found on www.abovalve.com.

DESIGN BENEFITS

1) NITRIDATED OR STELLITED DISC OPTION

Disc is provided nitridated as standard, stellited disc is an option.



3) SPIRAL SEAT

The gasket is spiral wound SS/Graphite for zero leakage. Spiral seat ensures free space for dilatation of the lamellar seat during extreme temperature service.

DETAIL



4) TRIPLE OFFSET

Triple offset design ensures safe function and tightness even in case of changing temperatures or case pressure peak. This geometry ensures that the bodies seal contacts the disc only at the final shut-off position without rubbing or galling.

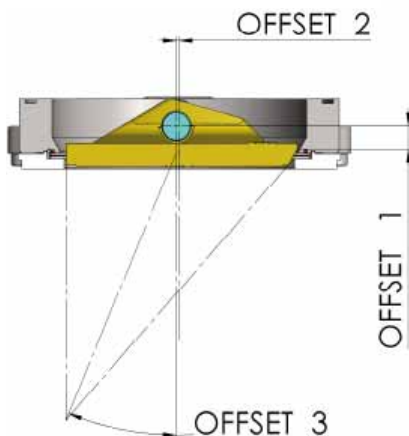

2) INTERNATIONAL STANDARD COMPATIBILITY

Top flange according to Standard ISO 5211 enables direct mounting of manual operators and power actuators. Longer necks of ABO butterfly valves result in insulation of ISO top flange (protection of mounted actuator), and further in complying with Heating Systems Regulation standards.



5) SPLIT SHAFT

Split shaft ensures favourable Cv/Kv and pressure loss factor.

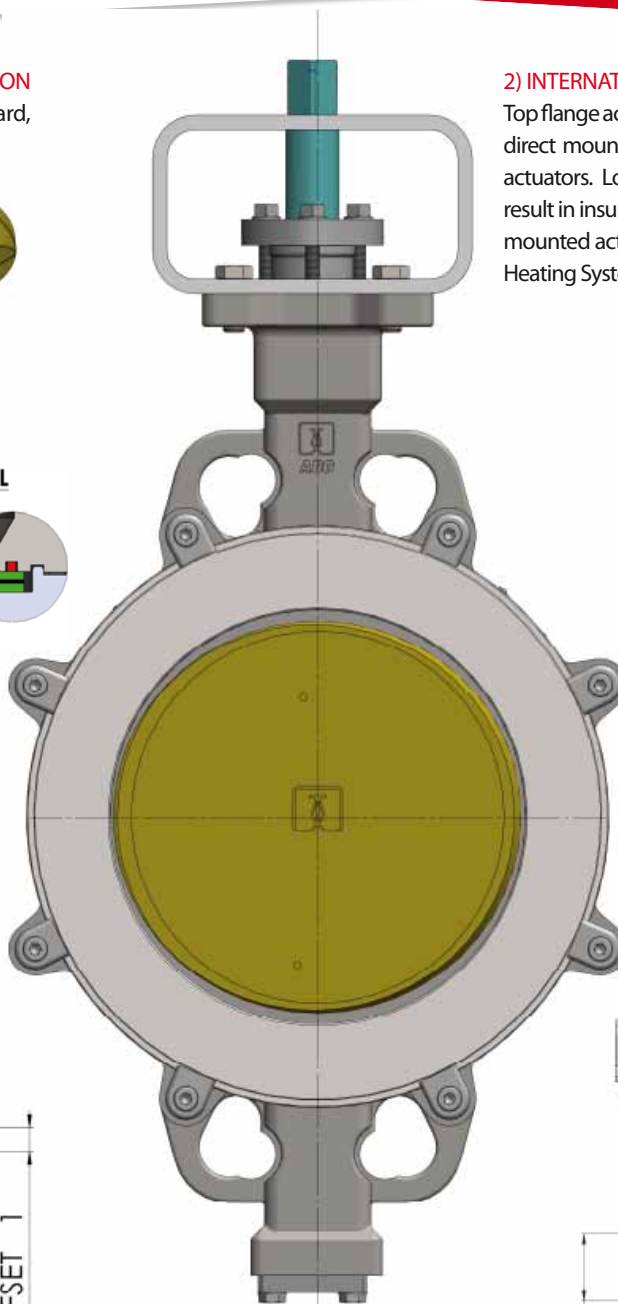
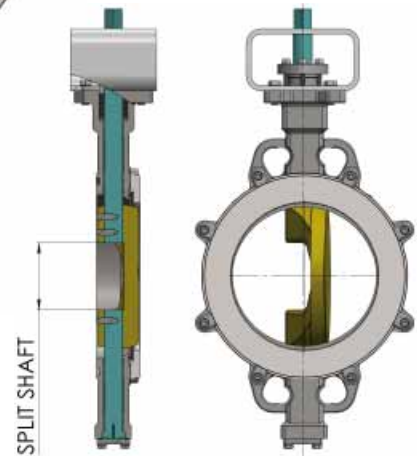

WHY TRIPLE ECCENTRIC VALVE?

- As cost of raw materials continues rising, a global shift towards more material and energy efficient products and technologies can be observed. In the valve industry, butterfly valves provide for significant cost savings over conventional valves such as ball, gate or globe valves due to an inherent reduction in materials and weight.
- With concentric butterfly valves; however, friction is constantly present throughout the operation cycle, thus subsequently reducing the life expectancy of such a valve. Double offset butterfly valves greatly decrease the friction to within the final degrees of closure, still resulting in a reduced life expectancy.
- ABO third offset design eliminates practically all friction throughout the operation cycle, therefore providing increased life expectancy and overall valve performance. Such friction elimination is possible thanks to conical machining profile of critical sealing components resulting in properly angled cone. This ensures friction free stroking throughout the entire operating cycle. Metal sealing components are never in contact with each other until final degree of valve closure with the 90° angle acting as a mechanical stop; resulting in "no over – travel" of the disc seat.

MATERIALS & TECHNICAL INFORMATION

DRAWING & MATERIALS

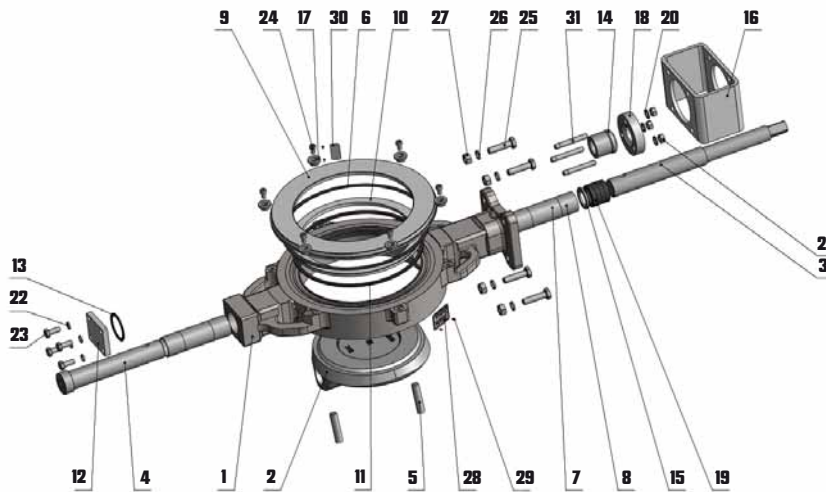

Execution in other material types can be provided upon request. Choice of the seat and disc materials for various media will be recommended upon specific enquiry.

Item	Name	Material
1	Body	7-Stainless steel 1.4539 (Uranus B6)
		6-Low carbon content steel 1.1156 (A352 LCC)
		5-Carbon Steel 1.0625 (A216 WCB)
		4-Stainless Steel 1.4408 (A351 CF8M)
2	Disc	7 - Stainless steel 1.4539 (Uranus B6)
		5 - Carbon steel 1.0446, 1.0619, 1.0625 (A216 WCB) nitridated
		5s - Carbon steel 1.0446, 1.0619, 1.0625 (A216 WCB) + Stellite
		4 - Stainless steel 1.4401 (AISI 316) - for ss body up to DN 300
		Stainless steel 1.4021 (AISI 420) - for WCB body DN 350-400 Stainless steel 1.4408 (CF8M) - for ss body DN 350-400 - all discs are nitridated (on customer's request can be Stellite: 4s)
3	Shaft	Stainless steel 1.4021 (AISI 420)/ 1.4462 Duplex
4	Pivot	Stainless steel 1.4021 (AISI 420)/ 1.4462 Duplex
5	Pin	Stainless steel 1.4021 (AISI 420)/ 1.4462 Duplex
6	Flange seal	Graphite 98%
7	Sleeve	Stainless steel 1.4404 (AISI 316L)
8	Sleeve	Stainless steel 1.4404 (AISI 316L) + Ni
9	Flange	Carbon steel 1.0553 (A441) + Zn/ Stainless steel 1.4404 (AISI 316L)
10	Seat	L-Stainless steel 1.4401 (AISI 316) + Graphite 98%
11	Seal	Graphite
12	Cover	Carbon steel 1.0553 (A441) / Stainless steel 1.4401 (AISI 316)

Item	Name	Material
13	Cover seal	Graphite 98%
14	Packing gland	Stainless steel 1.4401 (AISI 316)
15	Lock washer	Stainless steel 1.4401 (AISI 316)
16	Bracket	Carbon steel 1.0553 (A441)
17	Retaining sleeve	Stainless steel 1.4401 (AISI 316)
18	Gland flange	Stainless steel 1.4301 (CF8)
19	Packing	Graphite
20	Washer	Stainless steel A4
21	Hex nut	Stainless steel A4
22	Washer	Stainless steel A4
23	Bolt	Stainless steel A4
24	Screw	Stainless steel A4
25	Bolt	Stainless steel A4
26	Washer	Stainless steel A4
27	Hex nut	Stainless steel A4
28	Name plate	-
29	Rivet	Stainless steel A4
30	Plate	-
31	Stud	Stainless steel A4

Other material upon request.

COATING

- Black painting FINALUX Decklack 872-75 – 60 - 80 µm
- Based on customer's request, higher degree of coating can be provided

INSTALLATION BETWEEN FLANGES (DN 150-400) TYPE B

PN / DN	150	200	250	300	350	400
ISO PN 6	●	●	●	●	●	●
ISO PN 10					●	●
ISO PN 16						
ISO PN 25						
ISO PN 40						
Class 150						
Class 300					x	x
JIS 10K		●		●	●	●
JIS 16K	●					

	standard
x	not suitable
●	suitable with additional machining

For lug type (T) installation, please specify in the inquiry.

ACTUATION & TORQUES

ACTUATION POSSIBILITIES

All ABO handles, manual gear operators, pneumatic and electric actuators can be mounted directly to ABO butterfly valves, thus eliminating brackets or couplings. This allows for simple installation in the field, minimizes possible misalignment and decreases overall height.

MANUAL GEARBOX WITH HANDWHEEL

ABO gearbox series of manual actuators combines state of art production technology, with cast iron and pressed steel construction, to provide a smooth and trouble-free operation for heavy duty on-off and throttling service of ABO valves. The rugged, cast iron body seals is weatherproof to IP65. A self-locking gearing holds the valve in the desired position. Further features include a readily accessible handwheel, adjustable stopcrew for closed position, removable splined drive bush with indexing facility and a facility to lock handwheel with padlock and chain. Gearboxes, as well as handlevers, can be supplemented with contacts for signalization of endpoints.

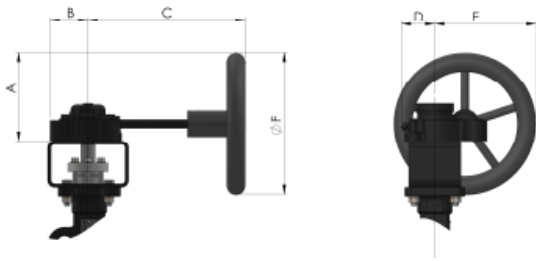

DN	150	200	250	300	350	400
A	155	155	213	213	275	275
B	66	66	83	83	99	126
C	272	272	345	345	285	337
D	59	59	70	70	86	114
E	177	177	242	242	315	348
F	250	250	350	350	450	450
Weight	3,7	3,7	6,6	6,6	14,5	27,2

Dimensions mentioned in mm, weight in kg. Weight is approximate, and is dependent on the customers' selection of gearbox.

ACTUATORS

- **ELECTRIC ACTUATORS** - ABO series 97 electric actuators are designated for quarter turn operating application. Electric actuators of 24V, 230V and 400V can be installed on ABO butterfly valves.
- **PNEUMATIC ACTUATORS** - ABO pneumatic actuators Series 95 are rack and pinion, opposed-piston actuators available in two versions: single acting & double acting

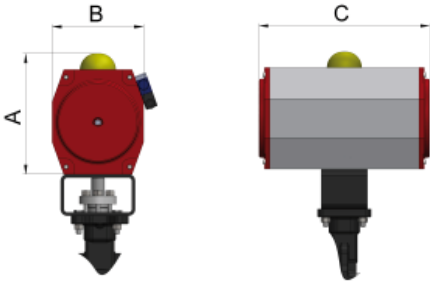

DN	150	200	250	300	350	400
A	198	198	198	255	302	360
B	172	172	172	224	272	360
C	332	332	374	422	603	683
Weight	15,8	15,8	21	37,75	70,6	107

Dimensions mentioned in mm, weight in kg.

OPERATING TORQUES UPON WORKING PRESSURE (NM)*

Open torques (Nm)

DN	150	200	250	300	350	400
10 bar	110	280	283	600	1 100	1 600
16 bar	140	330	418	900	1 500	2 270
20 bar	190	370	460	1 030	1 900	2 430
25 bar	210	490	656	1 150	2 500	3 100
30 bar	261	550	-	-	-	-
40 bar	350	-	-	-	-	-

Operating torques are mentioned without safety reserve.

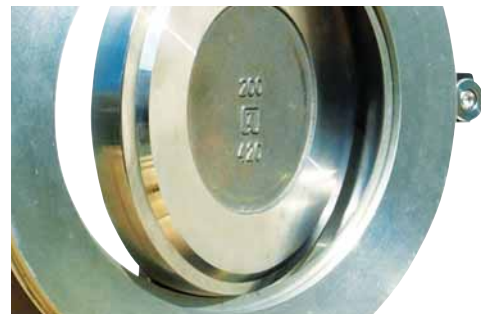

DN	150	200	250	300	350	400
Closed torque (water)	220	450	420	400	450	500
Closed torque (air)	220	450	565	550	1000	1 300
Max. torque on shaft - 35Lx	635	635	1 097	1 742	2800	5 078
Max. torque on shaft - 34Lx	476	476	822	1 300	2 300	3 800

Operating torques are mentioned without safety reserve.

WORKING CONDITIONS, DIMENSIONS DN 150 - 400 (6" - 16"), PN 10 & 16

WORKING CONDITIONS

Working pressure	DN 150: 40 bar DN 200: up to 30 bar DN 250 - DN 400: 25 bar	Working temperature	max temperature range: - 100°C + 500°C with WCB body - 29°C + 425°C with CF8M body - 100°C + 500°C
-------------------------	---	----------------------------	--

Max. temperatures for each material of seat are accepted only for a specific medium and short time exposure.

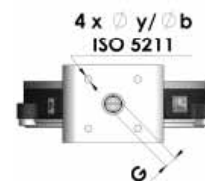
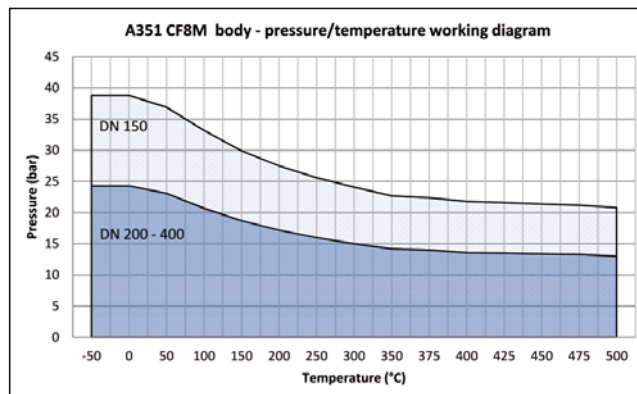
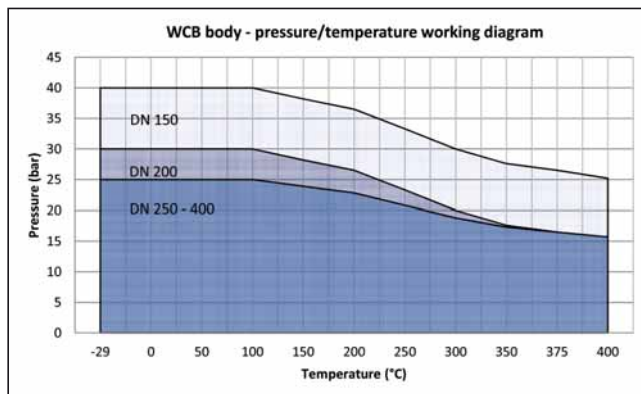

DN		d1	d2	A	B	C	D1	D3	S1	S2	E	G	ISO 5211	y	b	Weight (kg)	
mm	inch															Version B	Version T
150	6"	146	155	307	214	57	252	318	136	143	25	17	F10	11	102	21	28
200	8"	194	204	339	246	61	305	381	185	193	25	17	F10	11	102	29	41
250	10"	238	259	395	275	69	349	450	224	236	31	22	F12	13	125	46	70
300	12"	287	309	460	313	79	393	521	270	284	31	27	F14	17	140	67	105
350	14"	323	342	508	355	92	448	557	300	308	45	27	F16	22	165	91	140
400	16"	385	405	556	402	103	542	657	342	360	58	36	F16	22	165	132	211

Other dimensions upon request.



EUROPEAN UNION
EUROPEAN REGIONAL DEVELOPMENT FUND
INVESTMENT IN YOUR FUTURE

All statements, technical information in this brochure are tentative and for general use only and do not constitute a recommendation or guarantee for any specific service or application requirement. Consult ABO representative or factory for specific requirements and material selection for your intended application. The right to change or modify product design or product without prior notice is reserved. Binding specification will be provided in each offer. ABO valve accepts no liability for damages caused by bad interpretation or use of the information included in this brochure.

30. 10. 2014

Data subject to change.

Company HQ – Czech Republic:
ABO valve, s.r.o.
Dalimilova 285/54, 783 35 Olomouc
Tel: +420 585 202 226, +420 585 224 087
Email: export@abovalve.com
www.abovalve.com

Slovakia:
ABO Slovakia, s.r.o.
Banská Bystrica
Tel: +421 484 145 633
Email: aboslovakia@aboslovakia.sk
www.aboslovakia.sk

Russia:
ABO ARMATURA Ltd.
Smolensk
Tel: +7 4812 31 28 27
Email: aboarmatura@yandex.ru
www.aboarmatura.ru

Singapore:
ABO Valve Pte. Ltd.
Singapore
Tel: +65 6383 4368
Email: lsw@abovalve.com
www.abovalve.com

China:
ABO Flow Control
Beijing
Tel: +86 13601522831
Email: wen@abovalve.com
www.abovalve.com

Bahrain:
ABO Middle East
Kingdom of Bahrain
Tel: +973 - 7700 2436
Email: jimichen@abovalve.com
www.abovalve.com