

ABO valve

ABsOlute flow control

SERIES 500

- // PN 6/10/16/Classs 150
- // DN 50 - 200 (2" - 8")
- // Chemical industry
- // Aggressive media
- // Acids



PTFE LINED HIGH PERFORMANCE
BUTTERFLY VALVES

GENERAL INFORMATION - SERIES 500

GENERAL CHARACTERISTICS

- DN 50 – DN 200
- Maximum working pressure: **10 bar**
- Concentric design with epoxy coated body
- Shut-off and regulating device
- No limits in position in piping (horizontal/vertical)
- Excellent shut off protection (bubble tight shut off) and high KV values
- Disc has 3 mm thickness of pure virgin PTFE
- Upper stem seal system prevents any environmental contaminants from entering the stem bore
- Extended neck design allows for piping insulation and enables easy access for actuator mounting
- PTFE impregnated steel bearing ensures precision alignment of the upper and lower stem
- Vacuum service possible depending on medium and temperature - consult with manufacturer
- Top flange acc. to ISO 5211 allows connection with various kinds of actuators (electric, pneumatic, hydraulic etc.)

APPLICATIONS

High performance butterfly valves Series 500 are designed to work with aggressive media in industries such as:

- Chemical industry
- High purity water
- Food industry
- Pharmaceutical industry
- Sanitary industries
- Corrosive & toxic media
- Adhesive & acids
- Paper industry
- Chlorine production
- Mining industry
- Paint manufacture

STANDARDS

<u>LEAK TEST:</u>	<u>FACE TO FACE ACC.:</u>	<u>TOP FLANGE:</u>	<u>CONNECTION BETWEEN FLANGES:</u>	<u>WORKING STANDARD:</u>	<u>MARKING:</u>
• EN 12266-1, Rate A	• EN 558, SERIES 20	• EN ISO 5211	• EN 1092-1	• EN 593 + A1	• EN 19
• ISO 5208, Rate A	• ISO 5752, SERIES 20		• DIN 2631-32		
• API 598, TAB. 5	• API 609, TAB. 2		• ASME B16.5		

TYPE DESIGNATION

5 9 9 B

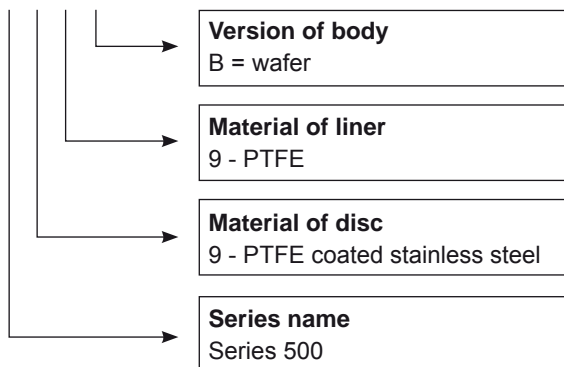

Models
Wafer type B

PRODUCT QUALITY AND CONTROL

ABO production facilities are certified in accordance with ISO 9001 quality system, which ensures product quality and precision in manufacturing as well as strict product testing. Quality control guidelines and procedures include number of steps in 3 main areas: incoming materials control, in-production control and after-production control.

- Test procedures are established according to: EN 12266-1, ISO 5208, API 598, ANSI/FCI 70-2
- Manufacture according to the requirements of the European Directive 97/23/CE – Equipment under pressure (Category III, modul B)
- All ABO valves pass pressure tests to 110% of rated pressure to ensure bubble tight shutoff
- All actuators are calibrated and cycle tested before shipment
- Material Traceability Rule – Certification is provided for all supplied valves as per customer's request
- Positive Material Identification – All materials are subjected to PMI testing in order to verify Material Traceability Certificate

Certificates - Complete list of certificates can be found on www.abovalve.com.

DESIGN BENEFITS

1) SHAFT DESIGN

Splitted shaft system and highly profiled disc ensure high Kv (Cv) value and lower pressure drop. ABO splitted shaft system also offers bigger cross section area comparing to single-pieced shaft versions.

2) INTERNATIONAL STANDARD COMPATIBILITY

Top flange according to Standard ISO 5211 enables direct mounting of manual operators and power actuators. Longer necks of ABO butterfly valves result in insulation of ISO top flange (protection of mounted actuator) and meeting Heating Systems Regulation standards.

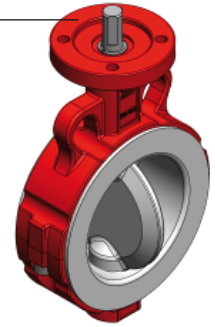

3) SELF-LOADED ENERGIZED STUFFING BOX

No up-movement of shaft is guaranteed by spring in the body neck.

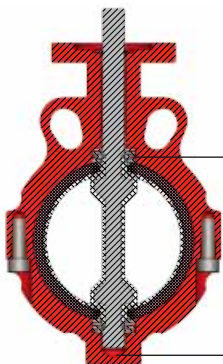

4) RUBBER ENERGIZER

Rubber energizer to ensure the even tension against the whole perimeter of the disc.

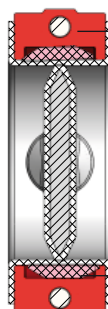

5) SEAT DESIGN

Seat, disc and stem casted together, encapsulated in PTFE to protect the body of the valve against the impact of liquid.

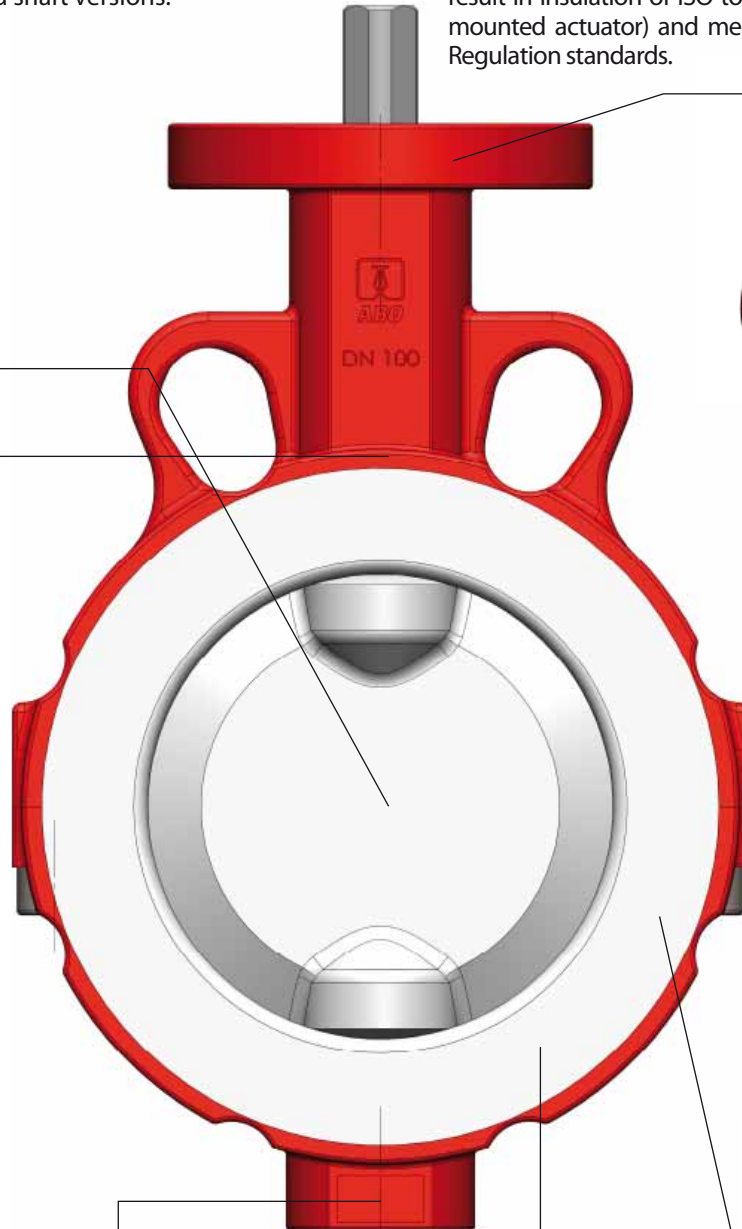
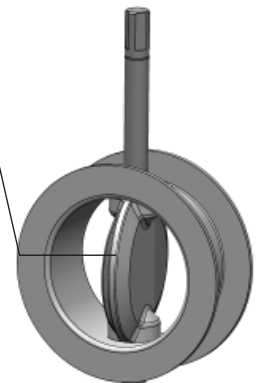

MATERIALS & TECHNICAL INFORMATION

DRAWING & MATERIALS

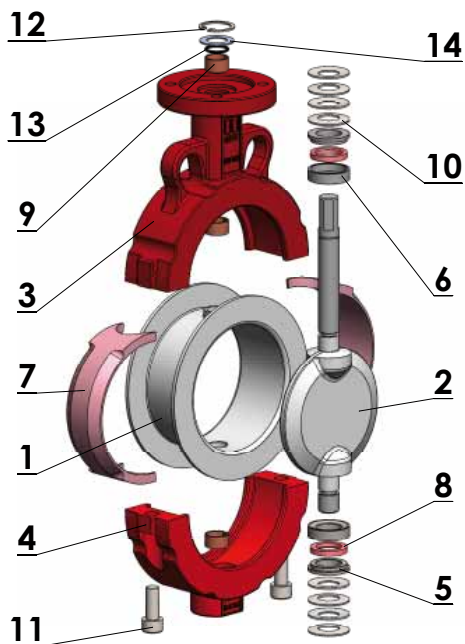

Item	Name	Material
1	Liner	PTFE
2	Disc with shaft	Stainless steel 1.4469, PTFE coated
3	Upper body part	Ductile iron 0.7043 (GGG40.3)
4	Lower body part	Ductile iron 0.7043 (GGG40.3)
5	Pressure element	Stainless steel 1.4408 (CF8M)
6	Seal capsule	Stainless steel 1.4408 (CF8M)
7	Energizer	Silicone rubber / VITON
8	Ring	Silicone rubber
9	Sliding gland ring	SKF PTFE
10	Disc spring	Carbon steel 1.8159
11	Screw	Stainless steel A4
12	Retaining ring	Stainless steel 1.4122
13	O-ring	NBR
14	Lock Washer	Stainless steel 1.4404 (AISI 316L)

Execution in other material types can be provided upon request. Choice of the seat and disc materials for various media will be recommended upon specific enquiry. Max. temperatures for each material of seat are accepted only for a specific medium and short time exposure. Please always consult material selection with the manufacturer.

ABO VIRGIN PTFE PROPERTIES

In order to assure long-life span and superior quality, all PTFE parts (seats as well as encapsulated discs) for ABO Series 500 valves are moulded from pure, virgin PTFE material. Virgin PTFE provides for an excellent chemical resistance and can be used with aggressive media. Typical characteristics of fluoropolymer resins include chemical inertness, exceptional dielectric properties, toughness and flexibility, low coefficient of friction, negligible water absorption and non-stick characteristics. All these properties provide increased protection against permeation of the line media. Further, low coefficient of friction reduces valve operation torque.

INSTALLATION BETWEEN FLANGES (DN 50 - 200)

Vers.	PN / DN	50	65	80	100	125	150	200
B	PN 6							
	PN 10							
	PN 16							
	Class 150							
	JIS 10K							•
	JIS 16K						•	•

standard
 upon request

WORKING CONDITIONS

- Maximum working pressure: 10 bar
- Temperature range - max: -40°C + 200°C (-40°F + 392°F), depending on medium

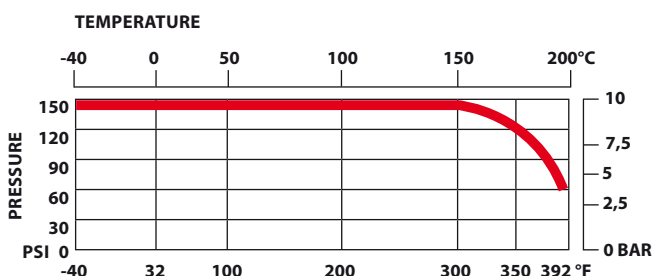

COATING OPTIONS

ABO's standard product offers valve bodies with an epoxy coating, providing excellent wear as well as corrosion resistance to the valve's surface. ABO epoxy coating is executed in orange finish RAL 2002 – 80 µm. Based on customer requirement, other customer specific coatings or colors are available. ABO epoxy coating has the following features:

- Excellent corrosion and wear resistance
- Resistance of chemicals including dilute acids and alkalis, petroleum solvents, alcohols, greases and oils
- Resistance to humidity & water
- Resistance to ultra - violet radiation
- Excellent resistance to abrasion
- Impact resistance without chipping or cracking



ACTUATION & TORQUES

ACTUATION POSSIBILITIES

All ABO handles, manual gear operators, pneumatic and electric actuators can be mounted directly to ABO butterfly valves, thus eliminating brackets or couplings. This allows for simple installation in the field, minimizes possible misalignment and decreases overall height.

MANUAL ACTUATION: HANDLEVER

For manual actuation, ABO offers levers in carbon steel material with protective coating for excellent corrosion, abrasion and impact resistance. A lever in stainless steel material is an option. ISO top flange connection is F05 for sizes DN 50 and 65, and F07 for sizes DN 80-200, respectively.

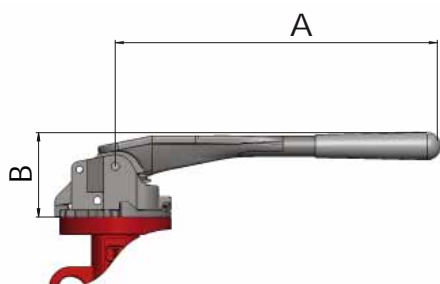

DN	mm	50-65	80-125	150-200
	inch	2"-2 1/2"	3"-5"	6"-8"
A		270	270	362
B		75	80	90
Weight (kg)		1,24	1,24	1,24

MANUAL GEARBOX WITH HANDWHEEL

ABO gearbox series of manual actuators combines state of art production technology, with cast iron and pressed steel construction, to provide a smooth and trouble-free operation for heavy duty on-off and throttling service of ABO valves. The rugged, cast iron body seal is weatherproof to IP65. A self-locking gearing holds the valve in the desired position. Further features include a readily accessible handwheel, adjustable stopscrew for closed position, removable splined drive bush with indexing facility and a facility to lock handwheel with padlock and chain. Gearboxes, as well as handlevers, can be supplemented with contacts for signalization of endpoints.

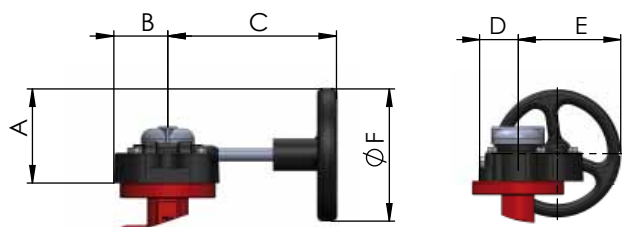

DN	mm	50 - 125	150 - 200
	inch	2" - 5"	6" - 8"
A		89	155
B		51	66
C		152	272
D		44	58,5
E		101	177
F		125	250
Gearbox		Series SE07	Series SE10

ACTUATORS

- PNEUMATIC ACTUATORS - ABO pneumatic actuators Series 95 are rack and pinion, opposed-piston actuators available in two versions: single acting & double acting
- ELECTRIC ACTUATORS - ABO series 97 electric actuators are designated for quarter turn operating application. Electric actuators of 24V, 230V and 400V can be installed on ABO butterfly valves.

OPERATING TORQUES UPON WORKING PRESSURE (NM)*

DN	mm	50	65	80	100	125	150	200
	inch	2"	2" 1/2"	3"	4"	5"	6"	8"
PMA 10bar		34	41	66	85	113	153	195

For pressure 10 bar - water at 20°C only.

DIMENSIONS DN 50 - 200 (2" - 8"), PN 6/10/16

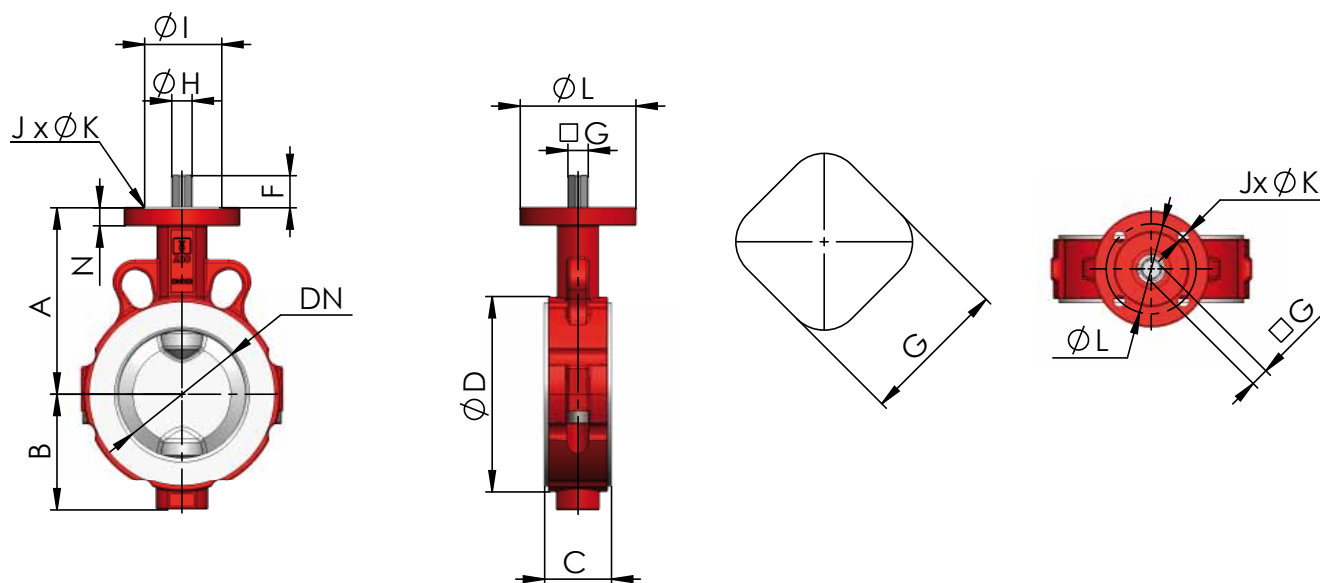

DN	mm	50	65	80	100	125	150	200
	inch	2"	2 1/2"	3"	4"	5"	6"	8"
Version B	A	120	128	135	145	164	176,5	234
Valve dimensions	B	61	74	78	90	106	126	152
	C	43	46	46	52	56	56	60
	D	96	115	131	152	181	207	257
	F	25	25	25	25	25	25	25
Endshaft dimensions	G	11	11	14	14	14	14	17
	H	-	-	-	-	-	-	-
	I	50	50	70	70	70	70	70
Top Flange	J	4	4	4	4	4	4	4
	K	7	7	9	9	9	9	9
	L	70	70	90	90	90	90	90
Flange dimensions	M	-	-	-	-	-	-	-
	N	14	14	14	14	14	14	14
	Weight (kg)	2,3	3,0	3,5	5,0	6,5	7,8	13,2
ISO Flange		F05	F05	F07	F07	F07	F07	F07



EUROPEAN UNION
EUROPEAN REGIONAL DEVELOPMENT FUND
INVESTMENT IN YOUR FUTURE

All statements, technical information in this brochure are tentative and for general use only and do not constitute a recommendation or guarantee for any specific service or application requirement. Consult ABO representative or factory for specific requirements and material selection for your intended application. The right to change or modify product design or product without prior notice is reserved. Binding specification will be provided in each offer. ABO valve accepts no liability for damages caused by bad interpretation or use of the information included in this brochure.

30. 5. 2014

Data subject to change.

Company HQ – Czech Republic:
ABO valve, s.r.o.
Dalimilova 285/54, 783 35 Olomouc
Tel: +420 585 202 226, +420 585 224 087
Email: export@abovalve.com
www.abovalve.com

Slovakia:
ABO Slovakia, s.r.o.
Banská Bystrica
Tel: +421 484 145 633
Email: aboslovakia@aboslovakia.sk
www.aboslovakia.sk

Russia:
ABO ARMATURA Ltd.
Smolensk
Tel: +7 4812 31 28 27
Email: aboarmatura@yandex.ru
www.aboarmatura.ru

Singapore:
ABO Valve Pte. Ltd.
Singapore
Tel: +65 6383 4368
Email: lsw@abovalve.com
www.abovalve.com

Brazil:
ABO Brasil
Simões Filho - Salvador
Tel: +55-71-8787-4599
Email: bernardo@abovalve.com
www.abovalve.com

Bahrain:
ABO Middle East
Kingdom of Bahrain
Tel.: +973 - 7700 2436
Email: jimnichien@abovalve.com
www.abovalve.com