

## WAFER STYLE KNIFE GATE VALVE

The **EX** model knife gate is an uni-directional wafer valve designed for general industrial service applications. The design of the body and seat assures non-clogging shut off on suspended solids in industries such as:

- Pulp and Paper
- Wastewater treatment plants
- Food and Beverage
- Mining
- Power plants
- Chemical plants
- Bulk handling
- etc.

**Sizes:** DN 50 to DN 1200 (larger diameters on request)

**Working pressure:** DN 50 to DN 250: 10 kg/cm<sup>2</sup>  
 DN 300 to DN 400: 6 kg/cm<sup>2</sup>  
 DN 450: 5 kg/cm<sup>2</sup>  
 DN 500 to DN 600: 4 kg/cm<sup>2</sup>  
 DN 700 to DN 1200: 2 kg/cm<sup>2</sup>

**Standard flange connection:** DIN PN 10 and ANSI B16.5 (class 150)

**Note:** other flange connections are available on request such as:

DIN PN 6                      DIN PN 16                      DIN PN 25  
 BS "D" and "E"              ANSI 125

**Directives:** DIR 98/37/CE (MACHINES)

DIR 97/23/CE (PED) Fluid: Group 1(b), 2 (Cat. I, mod. A)

DIR 94/9/CE (ATEX) Group II, Cat. 3: zones 2 and 22



All valves are tested prior to shipping in accordance with the standard developed by the Quality Control Department at ORBINOX.

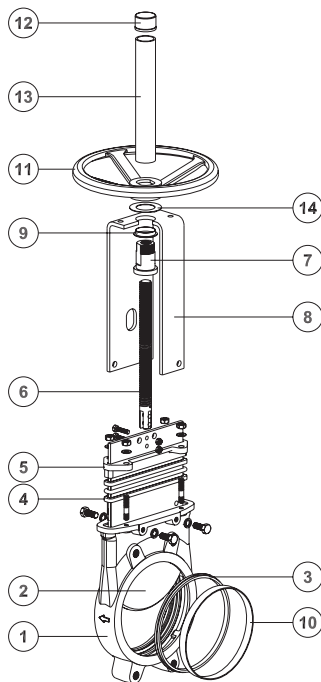

### STANDARD PARTS LIST

Part:	Cast Iron:	Stainless Steel:
1- Body	GJL250 (GG25)	CF8M
2- Gate	AISI 304	AISI 316
3- Seat	Metal/Metal or EPDM	
4- Packing	Tallowed cotton                      PTFE Impreg. Synth. Fibre (Both versions with a EPDM o-ring)	
5- Gland	Aluminium (DN 50 to DN 300) or Ductile Iron (DN 350 a DN 1000)	CF8M
6- Stem	AISI 303	
7- Stem nut	Brass	
8- Yoke	Epoxy-coated Carbon Steel	
9- Collar	Nylon	
10- "A" ring	AISI 304	AISI 316
11- Handwheel	∅ ≤ 310: Ductile Iron / ∅ ≥ 410: GJL 250 (GG25)	
12- Cap	Plastic	
13- Stem Protector	Epoxy-coated Carbon Steel	
14- Friction washer	Brass	

MODEL

**EX****DESIGN FEATURES****BODY:**

Wafer style cast **monoblock** with raised face, with reinforced ribs in larger diameters for extra body strength.  
 Internal cast-in gate wedges and guides allows for tighter shut-off.  
 Full port design for greater flow capacity and minimal pressure drop.  
 Internal design avoids any build up of solids that would prevent valve from closing.

**GATE:**

Stainless steel gate as standard.  
 Gate is polished on both sides to avoid jamming and seat damage.  
 Bottom of the gate edge is machined to a bevel to cut through solids for a tighter seal in the closed position. On request: thickness and/or material of the gate can be changed for higher pressure requirement.

**SEAT:** (resilient)

Unique design that mechanically locks the seat in the internal of the valve body with a stainless steel retainer ring.  
 Standard EPDM also available in different materials such as Viton, PTFE, etc.

**PACKING:**

Long-life packing with several layers of braided fibre plus an EPDM o-ring, with an easy access packing gland ensuring a tight seal.  
 Long-life braided packing is available in a wide range of materials.

**STEM:**

The standard stainless steel stem offers a long corrosion resistant life.  
 For rising stem handwheel actuators only, a stem protector is provided for additional protection against dust while the valve is in the open position.

**ACTUATORS:**

All actuators supplied by **ORBINOX** are interchangeable, and supplied with an standard mounting kit to allow for installation on site.

**YOKE or ACTUATOR SUPPORT:**

Made of EPOXY coated steel (stainless steel available on request).  
 Compact design makes it extremely robust even under the most severe conditions.

**EPOXY COATING:**

The epoxy coating on all **ORBINOX** cast iron and carbon steel valve bodies and components is electrostatically applied making the valves to be corrosion resistant with a high quality finished surface.  
 The **ORBINOX** standard colour is RAL-5015 **blue**.

**GATE SAFETY PROTECTION:**

**ORBINOX** automated valves are provided with gate guards in accordance with EU Safety Standards.  
 The design feature prevents any objects from being caught accidentally while the gate is moving.

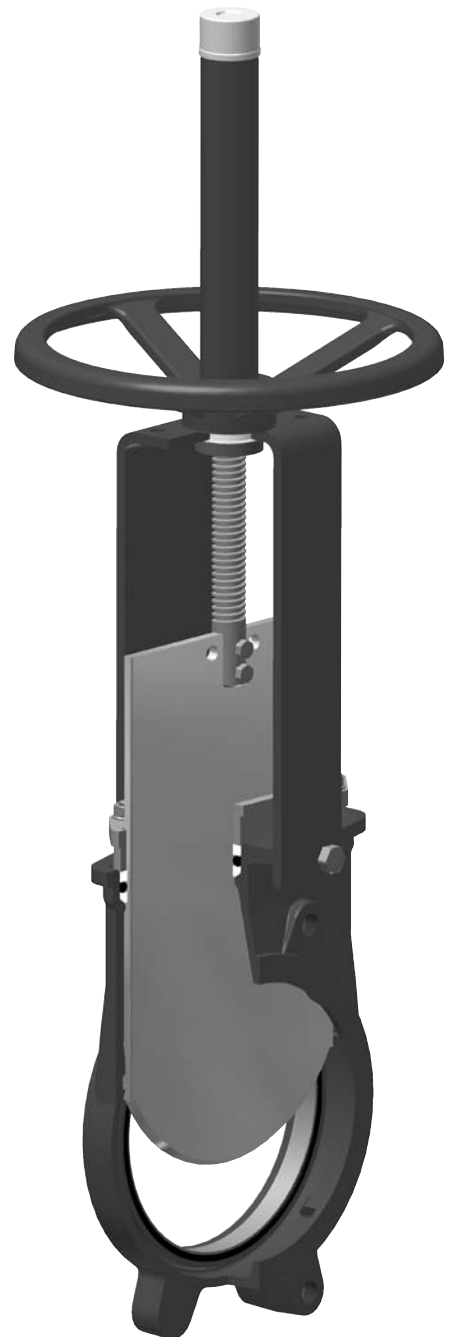

## OTHER OPTIONS

**Bonnet (Fig.1):**

Assures tight sealing to atmosphere for using with hazardous gas or fluids.

Reduces packing maintenance.

**V-port:**

60 degree and pentagonal port design.

Selection depends on type of fluid control desired.

**Flush ports (Fig.2):**

Allow for cleaning of solids trapped within the body cavities that can obstruct the flow or prevent the valve from closing.

Purging can be made with air, steam, liquids, etc. depending on the process.

**Other materials of construction:**

Special alloys such as AISI 317, 254SMO, Hastelloys, Titanium, etc.

**Fabricated valves:**

**ORBINOX** is equipped for in house fabrication of special valves. Depending on the design, diameter, pressures, construction material, etc.

**EXT (full lug design):**

Modified version of the EX model with full lug design for end of line applications.

Standard flange connection from DIN PN 10, ANSI 150, to AS "D".

Sizes available up to DN 600.

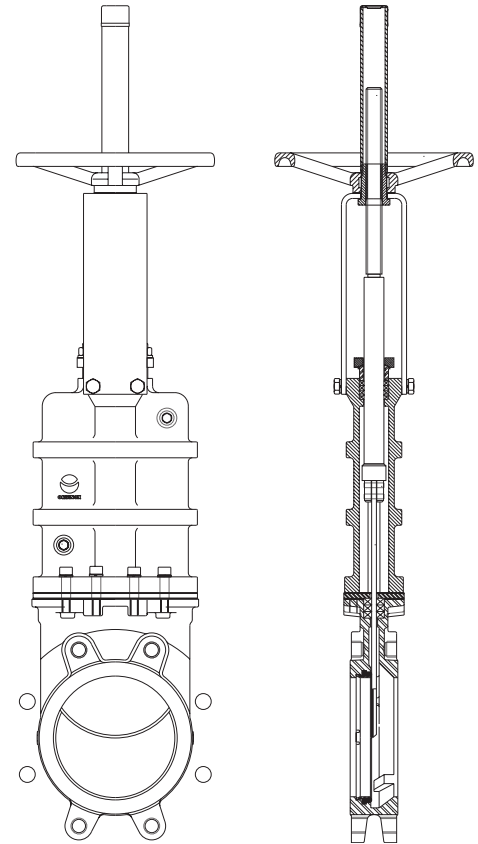

Fig.1

## SURFACE TREATMENTS

Valve components can be protected or coated for a longer life expectancy, depending on the application and the service conditions.

At **ORBINOX** we can offer treatments and coatings for the valve components to improve the properties against **abrasion** (Stellite, Polyurethane...), **corrosion** (Halar, Rilsan, Galvanised...) and **adherence** (Polishing, PTFE...).

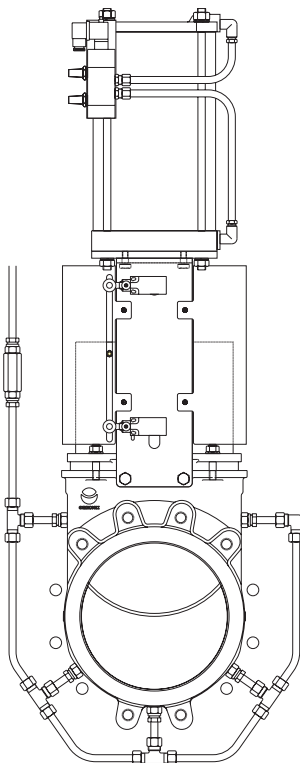

Fig.2

We recommend consultation with our technical department.

**ACTUATOR TYPES**

**Manual:**

- Handwheel (rising & non-rising stem)
- Chainwheel
- Lever
- Bevel Gear
- Other (square nut...)

**Automatic:**

- Electric
- Pneumatic
- Hydraulic

All actuators supplied by ORBINOX are interchangeable.

**Accessories:**

- Mechanical Stops
- Actuator manual override
- Positioners
- Proximity Switches
- Stem extensions

- Locking device
- Solenoid valves
- Limit Switches
- Floor stands

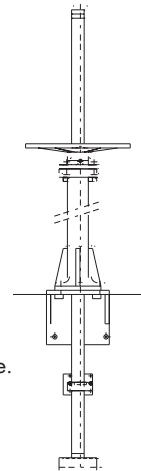

Wide range of valve extensions available.

Please consult our technical department.

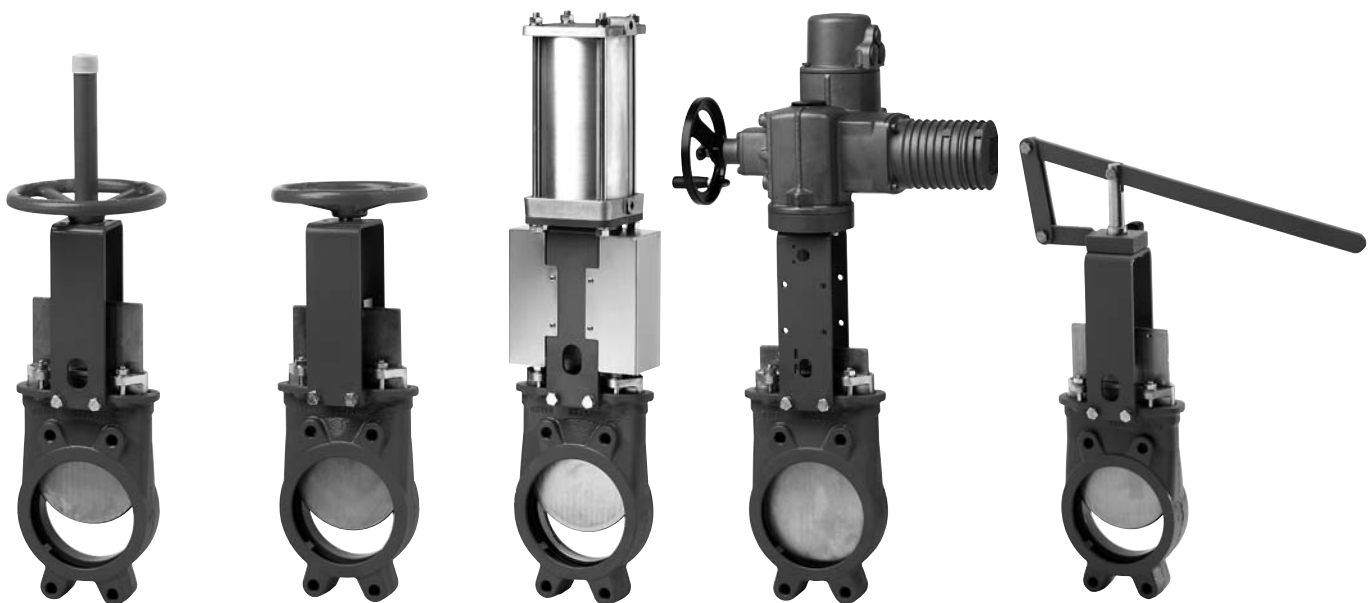

**Standard Handwheel (Rising Stem) Handwheel (Non Rising Stem)**

**Pneumatic Cylinder**

**Electric**

**Lever**

**TEMPERATURE CHART**

SEAT / SEALS			PACKING		
Material	Max.Temp.(°C)	Applications	Material	Max. Temp. (°C)	pH
Metal/Metal	>250	High temp. Low tightness.	Tallowed cotton (AH)	50	6 - 8
EPDM (E)	120	Acids and non mineral oils.	Dry cotton (AS)	50	6 - 8
Nitrile (N)	120	Resistance to petroleum products.	PTFE impregn. synth. fibre (ST)	240	2 - 13
Viton (V)	200	General chemical service.	Braided PTFE (TH)	260	0 - 14
		High temperature.	Graphited (GR)	600	0 - 14
Silicone (S)	250	Food service. / High temperature.	Ceramic fibre (FC)	1200	—
PTFE (T)	250	Corrosion resistance.			

NOTE: all types include an elastomere O-ring (same material as seal), excluding TH, GR and FC.

More details and other materials under request.

**SEAT TYPES**



**METAL / METAL**

For applications with:

- High temperature
- High density media application
- When full tightness is not required

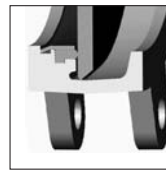

**RESILIENT, TYPE "A"**

- Standard resilient seat.
- Temperature limitations according to seat material selected. Consult the above chart or our technical department for more information.
- Replaceable seat retainer ring.



**TYPE "B" SEAT (metal/metal)**

For applications with:

- High temperature
- High density media application
- When full tightness is not required
- Replaceable design without dismantling the valve



**TYPE "B" SEAT (resilient)**

- Temperature limitations according to seat material selected. Consult the above chart or our technical department for more information.
- Replaceable and reinforced seat ring available in different materials such as: stainless steel, CA15, Ni Hard,...



**DEFLECTION CONE "C"**

- Deflects the media away from any internal exposed parts of the valve such as gate guides, seat, etc.
- Different types of material available such as AISI 316 stainless, CA15, Ni-Hard, etc.

Face to face dimension increase:

DN 50 to DN 250 X = 9mm

DN 300 to DN 600 X = 12mm

Larger diameters on request.

## VALVE EXTENSIONS

The extension on a valve allows the operator to open or close the valve from a distance. Different types of extensions can be used depending on the application and the distance from the gate to the actuator.

## 1.- Floor stand.

Mainly used to facilitate the operator in opening and closing the valve at normal operating level.

Required dimensions:

**H1:** distance from centre line of the pipe to the base of the floor.

**d1:** (wall bracket) distance from the wall to the face of the connecting flange.

## Notes:

**a-** Any type of actuator can be mounted on the floor stand such as Handwheel, Gear, Electric, etc.

**b-** A wall bracket (detail A) is recommended at every 1.5m. This prevents any deviation or buckling of the extension rod.

**c-** Standard construction of the floor stand is cast iron or carbon steel. Other materials are available on request. (Fig. 1)

**d-** A position indicator (optional) can be installed for easy visibility of the percentage of opening of the valve.

**e-** Possibility of construction of floor stand supports. (Fig. 2)

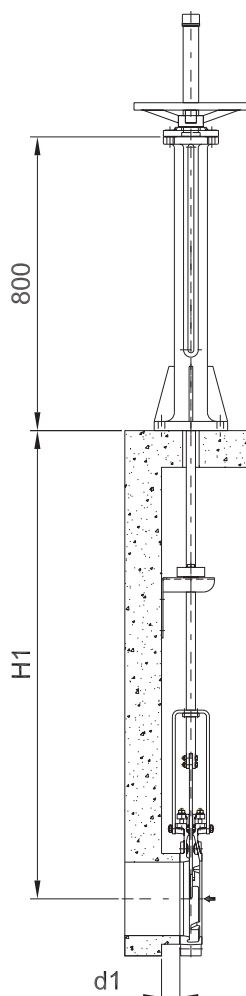
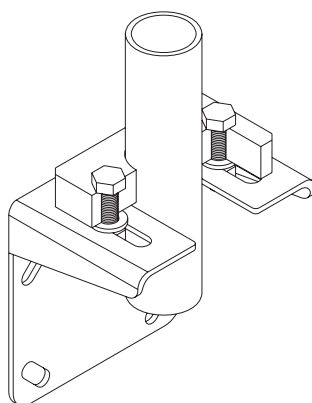

Fig. 1



Detail A.

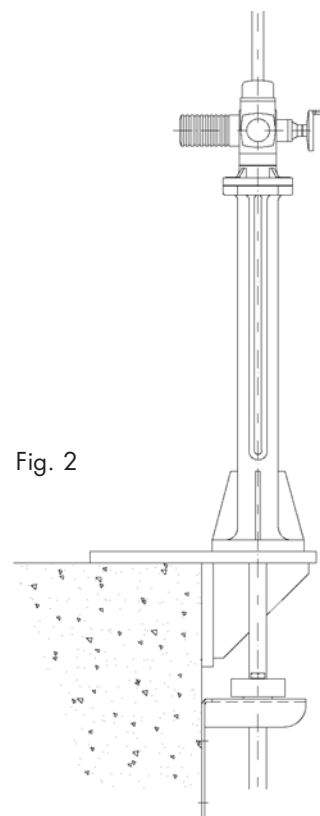
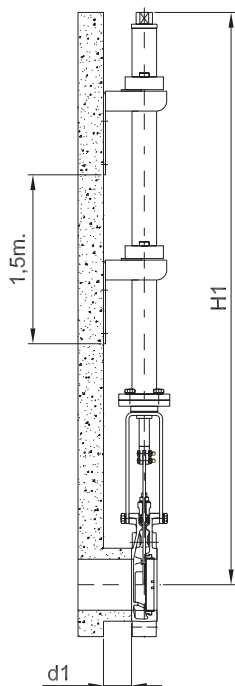

Fig. 2

## STANDARD PARTS LIST

Part:	Material:
Spindle	AISI 303
Stem	AISI 304
Wall bracket	Carbon Steel - Epoxy coated
Slider/bushing	Nylon
Floor stand	Cast Iron - Epoxy coated

## 2.- Tube



- Stem and yoke assembly remains in its original position.
- Handwheel is replaced by a tube, which rotates when operating the valve.
- Stem rises and lowers within the tube.
- Ideal for surface box operation, valve can be operated with a T-bar and a square nut.
- Required dimensions:

**H1:** distance from centre line of the pipe to the base of the floor.

**d1:** (wall bracket) distance from the wall to the face of the connecting flange.

### Notes:

1. Handwheel or square nut operated only.
2. A wall bracket (detail A) is recommended at every 1.5m. This prevents any deviation or buckling of the extension rod.
3. Standard construction of the extension is carbon steel epoxy coated. Other materials are available on request.

## 3 - Universal joint

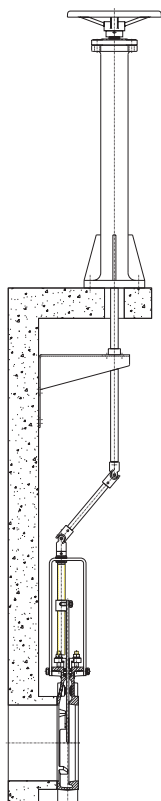

- Universal joints are installed between the rod extensions where a straight alignment is not available. Please contact our technical department for more information.

## 4 - Extended support plates

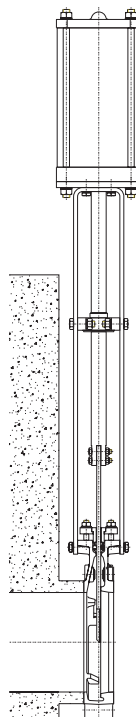

- Ideal where long extensions are not required.
- Guide bearing is installed at the mid point to prevent any deflection of the rod.

Please consult our technical department.

**HANDWHEEL (rising stem)**

- Standard handwheel actuator.
- Consists on:
  - Handwheel: Epoxy coated Cast Iron
  - Stem
  - Stem nut
  - Stem protector
- Available from DN 50 to DN 1000
- Options:
  - Locking Device
  - Extensions

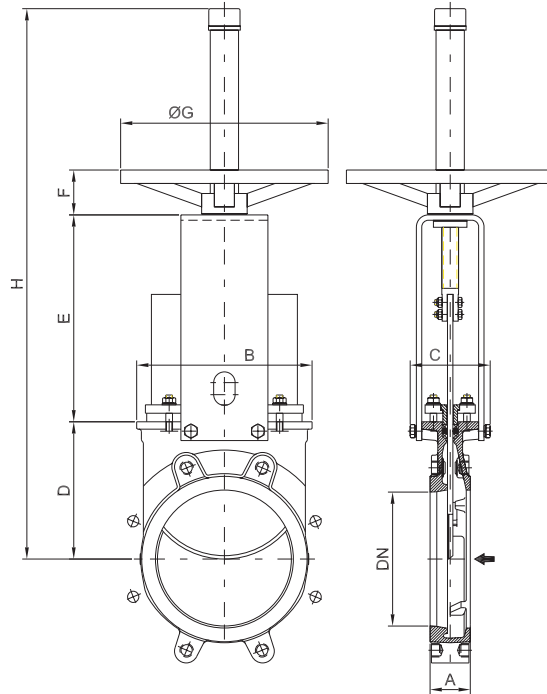

DN	A	B	C	D	E	F	ØG	H	Weight (kg.)
50	40	119	100	105	129	47	225	420	7
65	40	134	100	115	146	47	225	450	8
80	50	149	100	124	162	47	225	475	9
100	50	169	100	140	187	47	225	520	11
125	50	180	100	150	211	47	225	600	15
150	60	210	100	175	237	47	225	652	18
200	60	262	122	205	309	67	310	822	30
250	70	318	122	250	364	67	310	1022	44
300	70	372	122	300	414	67	310	1122	58
350	96	431	197	338	486	66	410	1323	96
400	100	486	197	392	536	66	410	1427	124
450	106	540	201	432	588	66	550	1594	168
500	110	602	201	485	648	66	550	1707	192
600	110	708	201	590	748	66	550	2022	245
700	110	834	380	686	890	74	800	2575	405
750	110	884	380	760	945	74	800	2704	455
800	110	1015	320	791	989	74	800	3479	512
900	110	1040	320	895	1118	74	800	3798	680
1000	110	1150	320	975	1220	74	800	3980	865



**HANDWHEEL (non-rising stem)**

- Recommended for installation where space is limited.
- Consists on:
  - Handwheel: Epoxy coated Cast Iron
  - Stem
  - Yoke bushing
  - Stem nut fixed to the gate
- Available from DN 50 to DN 1000
- Options:
  - Locking Device
  - Extension
  - Square Nut Drive

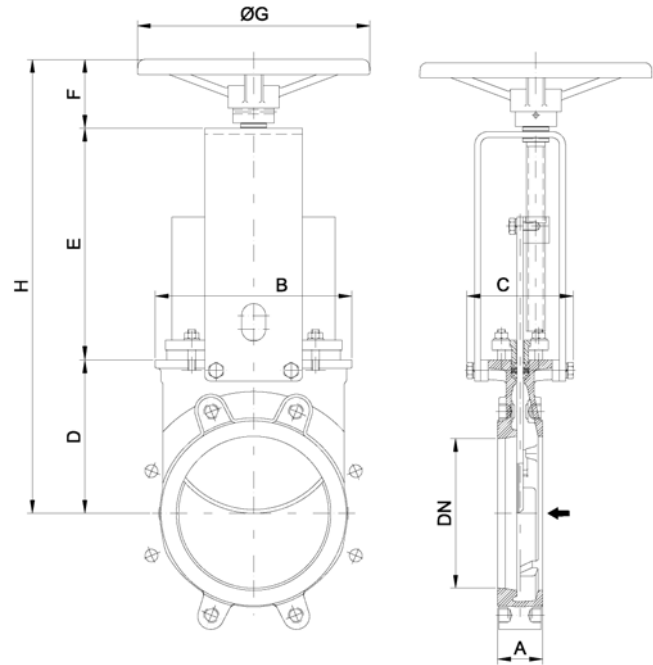

DN	A	B	C	D	E	F	ØG	H
50	40	119	125	105	132	78	225	315
65	40	134	125	115	149	78	225	342
80	50	149	125	124	165	78	225	367
100	50	169	125	140	190	78	225	408
125	50	180	125	150	214	78	225	442
150	60	210	125	175	240	78	225	493
200	60	262	142	205	305	92	310	602
250	70	318	142	250	360	92	310	702
300	70	372	142	300	410	92	310	802
350	96	431	197	338	487	110	410	935
400	100	486	197	392	537	110	410	1039
450	106	540	201	432	589	111	550	1132
500	110	602	201	485	649	111	550	1245
600	110	708	201	590	748	111	550	1449
700	110	834	380	686	890	150	800	1726
750	110	884	380	760	945	150	800	1855
800	110	1015	320	791	989	150	800	1934
900	110	1040	320	895	1118	150	800	2168
1000	110	1150	320	975	1220	150	800	2350

**CHAINWHEEL**

- Recommended for elevated installations.
- Consists on:
  - Chainwheel: Epoxy coated Cast Iron
  - Stem
  - Stem nut
  - Stem protector
- Available from DN 50 to DN 600
- Options (on request):
  - Locking Device
  - Extension
  - Non-rising Stem

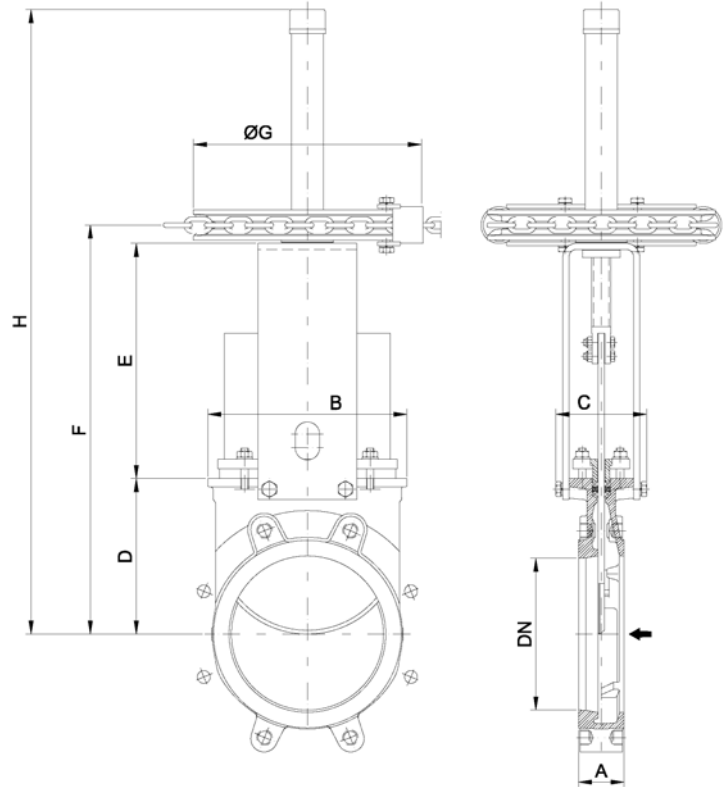

DN	A	B	C	D	E	F	ØG	H
50	40	119	100	105	129	253	225	424
65	40	134	100	115	146	280	225	451
80	50	149	100	124	162	305	225	476
100	50	169	100	140	187	347	225	518
125	50	180	100	150	211	380	225	601
150	60	210	100	175	237	431	225	652
200	60	262	122	205	309	538	300	822
250	70	318	122	250	364	638	300	1022
300	70	372	122	300	414	738	300	1122
350	96	431	197	338	486	856	454	1323
400	100	486	197	392	536	960	454	1427
450	106	540	201	432	588	1052	454	1589
500	110	602	201	485	648	1165	454	1707
600	110	708	201	590	748	1370	454	2022

**LEVER**

- Recommended for quick opening and closing.

- Consists on:
  - Lever
  - Stem
  - Yoke sleeve
  - Lever lock

- Available from DN 50 to DN 300

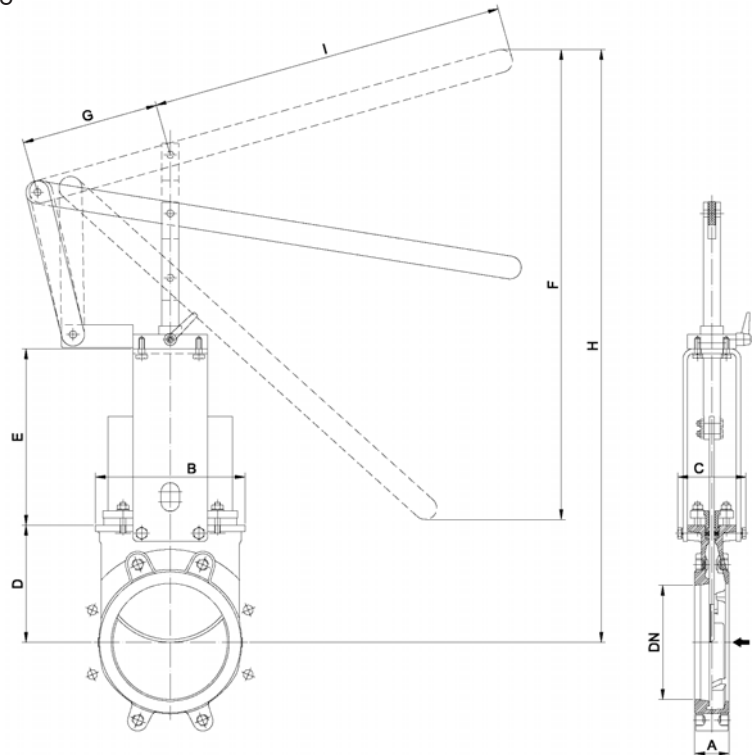

DN	A	B	C	D	E	F	G	H	I
50	40	119	100	105	129	256	150	408	315
65	40	134	100	115	146	259	150	435	315
80	50	149	100	124	162	307	150	509	315
100	50	169	100	140	187	378	150	637	415
125	50	180	100	150	211	439	150	755	415
150	60	210	100	175	237	529	150	895	415
200	60	262	122	205	309	620	235	1038	620
250	70	318	122	250	364	822	235	1307	620
300	70	372	122	300	414	995	235	1578	620

**GEAR**

- Recommended for valves larger than DN 350 and working pressures greater than 3.5 cm<sup>2</sup>
- Consists on:
  - Stem
  - Yoke
  - Bevel Gear Actuator with Handwheel (Standard Ratio 4:1)
- Available from DN 200 to DN1200
- Options:
  - Locking device
  - Extension
  - Chainwheel
  - Non-rising stem

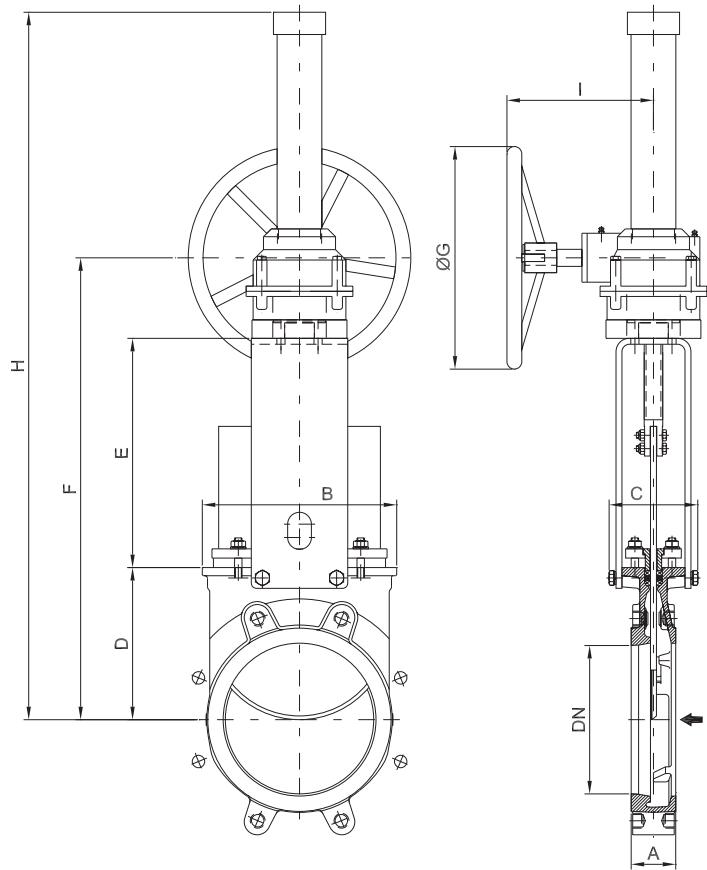

DN	A	B	C	D	E	F	ØG	H	I
200	60	262	122	205	309	623	300	964	198
250	70	318	122	250	364	723	300	1064	198
300	70	372	122	300	414	823	300	1164	198
350	96	431	197	338	500	922	450	1563	218
400	100	486	197	392	550	1026	450	1668	218
450	106	540	201	432	598	1114	450	1754	218
500	110	602	201	485	658	1227	450	1868	218
600	110	708	201	590	758	1432	450	2074	218
700	110	834	290	686	900	1660	450	2803	268
750	110	884	290	760	945	1789	650	2932	268
800	110	1015	320	791	968	1886	650	3029	307
900	110	1040	320	895	1118	2120	650	3263	307
1000	110	1150	320	975	1220	2302	650	3445	307
1200	150	1400	450	1230	1485	2820	850	4165	365

## PNEUMATIC CYLINDER

- The standard pneumatic actuator (double acting on-off cylinder) consists on:
  - Aluminium jacket and covers
  - Stainless steel (AISI 304) piston rod
  - Nitrile coated steel piston
- Available from DN 50 to DN 1000
- Supply Pressure: minimum 3.5 kg/cm<sup>2</sup> - maximum 10 kg/cm<sup>2</sup>
- For valves installed in a horizontal position, we recommend U-type support plates and/or actuator support.
- Options:
  - Hard anodized jacket and covers
  - Over / Undersized cylinder
  - Stainless steel jacket and covers
  - Manual override
  - Fail safe system (Page EX-14)
  - Travel stops
- Instrumentation (on request):
  - Positioners
  - Solenoid valves
  - Flow regulators
  - Air preparation units

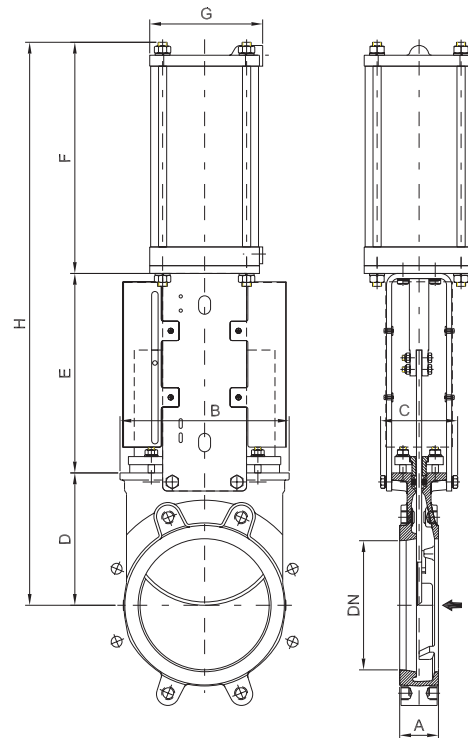

DN	A	B	C	D	E	F	G	H	Weight (kg.)	Standard Cyl	Connect.
50	40	119	100	105	129	178	115	412	9	C100/62	1/4" G
65	40	134	100	115	146	193	115	454	10	C100/77	1/4" G
80	50	149	100	124	162	211	115	497	11	C100/95	1/4" G
100	50	169	100	140	187	231	115	558	14	C100/115	1/4" G
125	50	180	100	150	211	271	140	632	20	C125/143	1/4" G
150	60	210	100	175	237	296	140	708	25	C125/168	1/4" G
200	60	262	122	205	309	358	175	872	44	C160/220	1/4" G
250	70	318	122	250	364	428	220	1042	67	C200/270	3/8" G
300	70	372	122	300	414	478	220	1192	82	C200/320	3/8" G
350	96	431	197	338	500	549	277	1387	135	C250/375	3/8" G
400	100	486	197	392	550	599	277	1541	165	C250/425	3/8" G
450	106	540	270	432	598	680	382	1710	220	C300/475	1/2" G
500	110	602	270	485	658	730	382	1873	280	C300/525	1/2" G
600	110	708	270	590	758	830	382	2178	330	C300/625	1/2" G
700	110	834	380	686	900	960	444	2546	520	C350/730	3/4" G
750	110	884	380	760	945	1020	444	2725	585	C350/780	3/4" G
800	110	1015	320	791	968	1095	444	2854	650	C350/830	3/4" G
900	110	1040	320	895	1118	1185	515	3203	850	C400/930	3/4" G
1000	110	1150	320	975	1225	1285	515	3485	1060	C400/1030	3/4" G

## FAIL SAFE SYSTEM

## SINGLE ACTING / SPRING RETURN

- This actuator (single acting cylinder) consists on:
  - Aluminium jacket and covers
  - Ductile Iron or carbon steel spring cap
  - Steel spring
  - Stainless Steel (AISI 304) piston rod
  - Nitrile coated steel piston
- Available from DN 50 to DN 200
- Supply pressure: minimum 5 kg/cm<sup>2</sup> - maximum 10 kg/cm<sup>2</sup>
- Options:
  - Fail open
  - Fail close

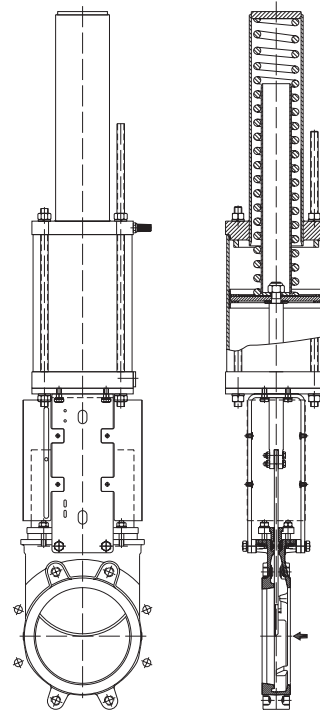

## SINGLE ACTING / VOLUME TANK

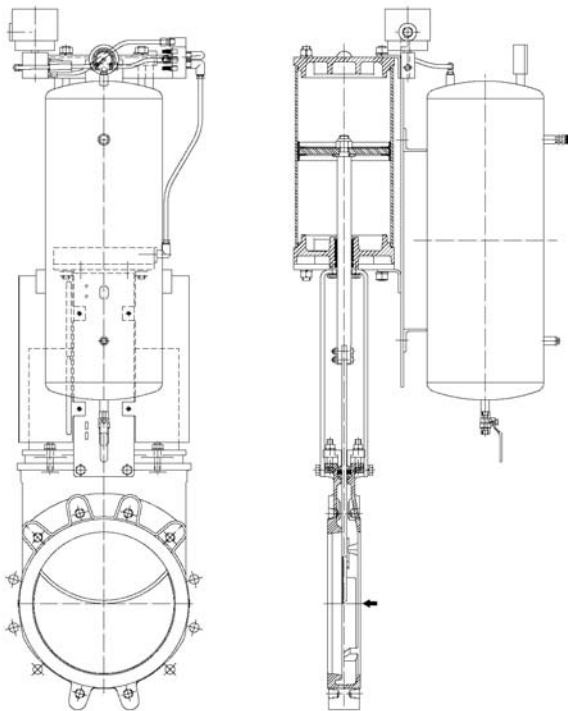

- For size DN250 and bigger safety system consists on: double acting pneumatic cylinder, volume tank and all the necessary elements according to the available options (solenoid valve, spool valve,...)
- Available for all diameters
- Supply Pressure: Minimum 3.5kg/cm<sup>2</sup>  
Maximum 10 kg/cm<sup>2</sup>
- Options:
  - 1- Pneumatic Failsafe
  - 2- Pneumatic or Electric Failsafe
- Option 2:

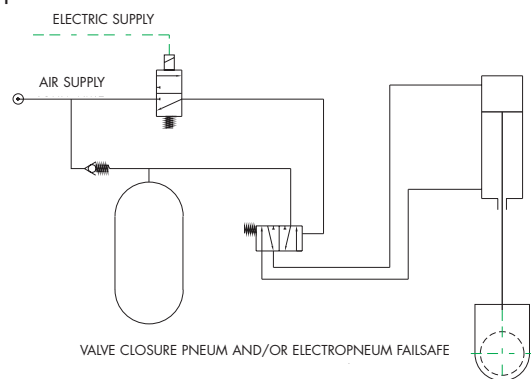

**ELECTRIC ACTUATOR**

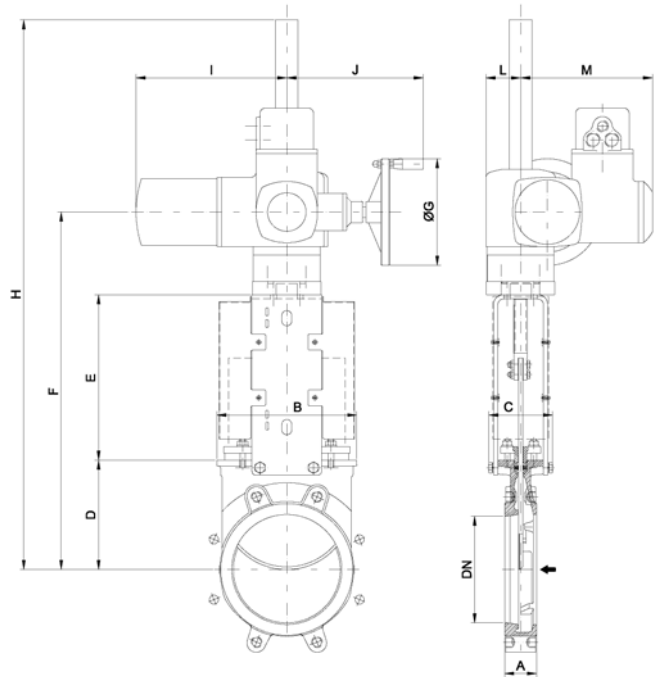

- Consists on:
  - Electric actuator
  - Rising stem
  - Motor support yoke flange  
(Acc. to ISO 5210 / DIN 3338)
- The standard electric motor is equipped with:
  - Manual emergency operation
  - Limit switches (open/closed)
  - Torque switches
- Available from DN 50 to DN 1200
- Wide range of types and marks available to meet customer's needs.
- Option:
  - Non rising stem



DN	A	B	C	D	E	F	ØG	H	I	J	L	M	stem Ø x pitch	Torque(Nm)
50	40	119	100	105	129	377	160	547	265	249	62	237	20 x 4	20
65	40	134	100	115	146	404	160	574	265	249	62	237	20 x 4	25
80	50	149	100	124	162	429	160	599	265	249	62	237	20 x 4	30
100	50	169	100	140	187	470	160	640	265	249	62	237	20 x 4	40
125	50	180	100	150	211	504	160	674	265	249	62	237	20 x 4	50
150	60	210	100	175	237	555	160	1125	265	249	62	237	20 x 4	60
200	60	262	122	205	309	669	200	1289	282	256	65	247	25 x 5	70
250	70	318	122	250	364	769	200	1349	282	256	65	247	25 x 5	80
300	70	372	122	300	414	869	200	1454	282	256	65	247	25 x 5	90
350	96	431	197	338	500	968	200	1553	282	256	85	247	35 x 6	105
400	100	486	197	392	550	1072	200	1657	282	256	85	247	35 x 6	120
450	106	540	270	432	598	1205	315	1805	385	325	90	285	35 x 6	160
500	110	602	270	485	658	1318	315	1918	385	325	90	285	35 x 6	180
600	110	708	270	590	758	1523	315	2223	385	325	90	285	35 x 6	210
700	110	834	380	686	900	1763	315	2846	385	325	90	285	40 x 7	230
750	110	884	380	760	945	1882	400	2965	385	332	90	285	40 x 7	260
800	110	1015	320	791	980	1948	400	3031	385	332	90	285	50 x 8	290
900	110	1040	320	895	1087	2157	400	3240	385	332	90	285	50 x 8	325
1000	110	1150	320	975	1200	2350	400	3431	385	332	90	285	50 x 8	370
1200	150	1400	450	1230	1485	3025	500	4330	510	355	115	310	60 x 9	650

FLANGE AND BOLTING DETAILS

DIN PN10

DN	K	n°	M	T	 
50	125	4	M-16	11	4 - -
65	145	4	M-16	11	4 - -
80	160	8	M-16	11	4 - 4
100	180	8	M-16	11	4 - 4
125	210	8	M-16	11	4 - 4
150	240	8	M-20	14	4 - 4
200	295	8	M-20	14	4 - 4
250	350	12	M-20	18	6 - 6
300	400	12	M-20	18	6 - 6
350	460	16	M-20	22	10 - 6
400	515	16	M-24	24	10 - 6
450	565	20	M-24	24	14 - 6
500	620	20	M-24	24	14 - 6
600	725	20	M-27	24	14 - 6
700	840	24	M-27	20	16 - 8
800	950	24	M-30	20	16 - 8
900	1050	28	M-30	20	20 - 8
1000	1160	28	M-33	20	20 - 8
1200	1380	32	M-36	30	22 - 10

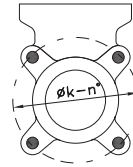

DN 50-65

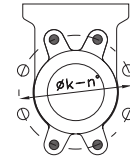

DN 80-200

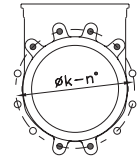

DN 250-300

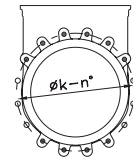

DN 350-400

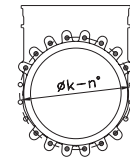

DN 450-600

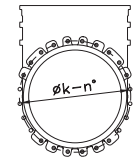

DN 700-800

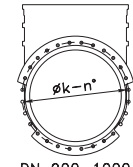

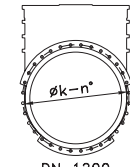

DN 900-1000



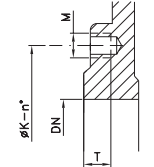

DN 1200



 BLIND TAPPED BOLTS  
 THROUGH BOLTS

ANSI B16.5, class 150(\*)

DN	K	n°	M	T	 
2"	4 3/4"	4	5/8" UNC	3/8"	4 - -
2 1/2"	5 1/2"	4	5/8" UNC	3/8"	4 - -
3"	6"	4	5/8" UNC	3/8"	4 - -
4"	7 1/2"	8	5/8" UNC	3/8"	4 - 4
5"	8 1/2"	8	3/4" UNC	3/8"	4 - 4
6"	9 1/2"	8	3/4" UNC	1/2"	4 - 4
8"	11 3/4"	8	3/4" UNC	1/2"	4 - 4
10"	14 1/4"	12	7/8" UNC	3/4"	6 - 6
12"	17"	12	7/8" UNC	3/4"	6 - 6
14"	18 3/4"	12	1" UNC	7/8"	8 - 4
16"	21 1/4"	16	1" UNC	1"	10 - 6
18"	22 3/4"	16	1 1/8" UNC	1"	10 - 6
20"	25"	20	1 1/8" UNC	1"	14 - 6
24"	29 1/2"	20	1 1/4" UNC	1"	14 - 6
28"	34"	28	1 1/4" UNC	3/4"	20 - 8
30"	36"	28	1 1/4" UNC	3/4"	20 - 8
32"	38 1/2"	28	1 1/2" UNC	3/4"	20 - 8
36"	42 3/4"	32	1 1/2" UNC	3/4"	22 - 10
40"	47 1/4"	36	1 1/2" UNC	3/4"	26 - 10
48"	56"	44	1 1/2" UNC	1 3/16"	28 - 16

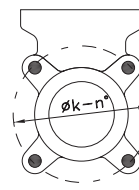

DN 2"-3"



DN 4"-8"

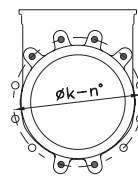

DN 10"-14"

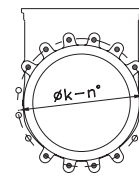

DN 16"-18"

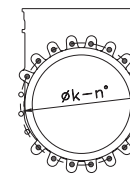

DN 20"-24"

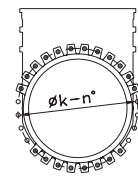

DN 28"-32"

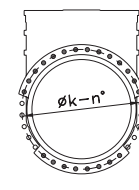

DN 36"

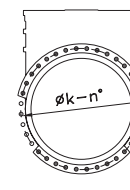

DN 40"

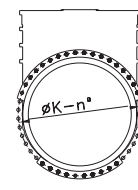

DN 48"

(\*) From DN 24", acc. to MSS SP 44 (class 150)