

HEGTOLDATOS ACÉLKARIMA

Welding neck

EN 1092-1 type 11

PN25

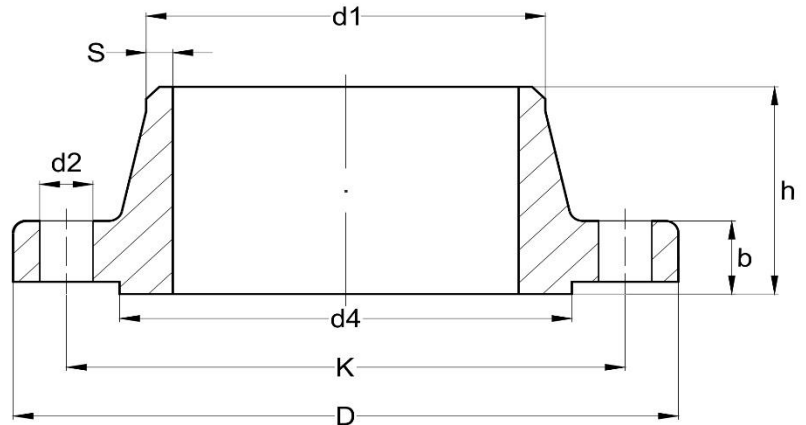

DN	D	k	d2	n	Csavar méret	d1	b	h	d4	s	súly (kg)
10-150	DN 10-től DN 150-ig azonos a PN40 hegtoldatos karimával										
200	360	310	26	12	M24	219,1	30	80	278	6,3	17,1
250	425	370	30	12	M27	273	32	88	335	7,1	24,3
300	485	430	30	16	M27	323,9	34	92	395	8	31,8
350	555	490	33	16	M30	355,6	38	100	450	8	48,8
400	620	550	36	16	M33	406,4	40	110	505	8,8	63,3
450	670	600	36	20	M33	457	46	110	555	8,8	76
500	730	660	36	20	M33	508	48	125	615	10	97
600	845	770	39	20	M36	610	48	125	720	11	121
700	960	875	42	24	M39	711	50	129	820	14,2	155
800	1085	990	48	24	M45	813	53	138	930	16	205
900	1185	1090	48	28	M45	914	57	148	1030	17,5	249
1000	1320	1210	56	28	M52	1016	63	160	1140	20	338

