

CARBON STEEL BALL PIVOT MONTHAHN

DN 65-150 PN 16

3.249.

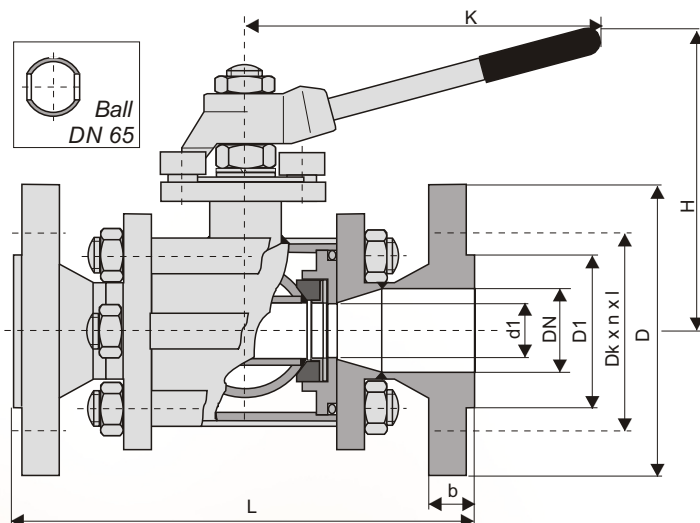

vtsz.8481808100

JOINING SIZE:

DIN 2501 (flanged)

GRADE OF SEEPAGE:

MSZ 4563-1983. 3.1.

DIN 3230/3 BO 1.

CONSTRUCTION OF LENGTH:

DIN 3201-F1 (flanged)

DIN 3202-S8 (welded)

AREA OF APPLICATION:

For cold and hot water, steam and for liquids to the material of the parts in the following range shown in the operational pressure-temperature diagram

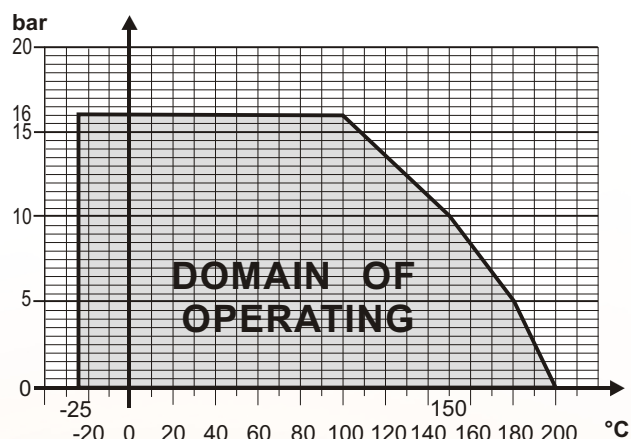

DN	d1	D1	Dk x n x l	D	L	b	H	K	kg/db
65	50	122	145 x 4 x 18	185	270	18	185	300	9,5
80	65	138	160 x 8 x 18	200	280	20	219	400	13
100	80	158	180 x 8 x 18	220	300	20	252	500	18
125	95	188	210 x 8 x 18	250	325	22	313	750	26
150	120	212	240 x 8 x 23	285	350	22	380	950	37

MATERIALS OF MAIN PARTS:

Specifying	Material quality (~)
Case	St. 37.0 DIN 1629
Ball	1.4301 MSZ EN 10088-1
Seat	PTFE + 25% Cg
Shaft	1.4021 MSZ EN 10088-1
Shaft sealing	2 db PTFE ring 1 db FPM "O" ring

DN	D2 x S	L	kg/db
65	76,1 x 2,9	270	5,6
80	88,9 x 3,2	280	7,8
100	108 x 3,6	300	14
125	133 x 4	325	23
150	159 x 4,5	350	33

TORQUE:

