

GENERAL INFORMATION - SERIES 900L

GENERAL CHARACTERISTICS

- DN 50 – DN 600
- Concentric design
- One pieced double flanged body
- Shut-off and regulating device
- Vulcanized seat
- Top flange acc. to ISO 5211 allows connection with various kinds of actuators (electric, pneumatic, hydraulic etc.)
- All bodies are drilled to be compatible with DIN PN10, PN16, and ANSI 150 side flange connection
- Bi-directional sealing

APPLICATIONS:

- Double flanged butterfly valves Series 900L are suited for wide range of industrial applications including
- Water and Wastewater
 - Potable Water
 - Food and Beverage
 - Chemical Processing
 - Marine
 - Desalination
 - Power
 - Transportation

STANDARDS

LEAK TEST:	FACE TO FACE ACC.:	END CONNECTION:	TOP FLANGE:
• EN 12266	• EN 558	• EN 1092	• EN ISO 5211
• ISO 5208	• ISO 5752-13	• DIN PN10/PN16	
• API 598		• ASME B16.5 CLASS150	

TYPE DESIGNATION

9	2	4	L
Version of body L = double flanged			
Material of disc 2 - Stainless steel 1.4308 (CF8) 3 - Ductile iron 0.7040 (GGG40) 4 - Stainless steel 1.4408 (CF8M) 7 - Duplex			
Material of seat 1 - NBR vulcanized 2 - EPDM vulcanized			
Series name Series 900L			

WORKING CONDITIONS

- Working pressure: 10 bar, 16 bar
- Working temperature: max temperature range:
- 20°C + 120 °C (- 4 °F + 248 °F) based on material selection



INSTALLATION BETWEEN FLANGES (DN 50 - 600)

Vers.	PN / DN	50	65	80	100	125	150	200	250	300	350	400	450	500	600
L	PN 10														
	PN 16														

For other connections, please consult with manufacturer.

PRODUCT QUALITY AND CONTROL

ABO production facilities are certified in accordance to ISO 9001 quality system, which ensures product quality and precision in manufacturing as well as strict product testing. Quality control guidelines and procedures include number of steps in 3 main areas: Incoming materials control, In-production control and After-production control.

- Test procedures are established according to: EN 12266-1, ISO 5208, API 598, ANSI/FCI 70-2
- Manufacture according to the requirements of the European Directive 97/23/CE – Equipment under pressure (Category III, modul B)
- All ABO valves pass pressure tests to 110% of rated pressure to ensure bubble tight shut-off
- All actuators are calibrated and cycle tested before shipment
- Material Traceability Rule – Certification is provided for all supplied valves as per customer's request
- Positive Material Identification – All materials are subjected to PMI testing in order to verify Material Traceability Certificate

Certificates

Complete list of certificates can be found on www.abovalve.com.

DESIGN BENEFITS

1) SEAT DESIGN:

a) ISOLATION FROM LINE MEDIA

Full rubber-lined valve interior completely isolates the line media, thus eliminating contacts between media and body. Shaft is designed as dry-shaft provision where the rubber lining is applied as protection against corrosive environments.

b) LONGER SERVICE LIFE

Vulcanized treatment prevents movement and misplacement of the seat under pressure, reduces shrinkage of the rubber during processing, increases seal surface precision and sealing property and therefore it increases the valve service life.

c) SMALLER OPERATING TORQUE

Vulcanized seat design lowers the opening and closing torque easing up operation of the valve as well as reducing cost of actuation.

2) INTERNATIONAL STANDARD COMPATIBILITY

The mounting top flanges meet ISO 5211 standard for direct mounting of handles, gear operators and actuators, which allows simple installation in the field, minimizes possible misalignment and reduces overall height.

3) BLOW-OUT PROOF SYSTEM

The shaft design includes blow-out proof system so no up-movement of shaft is guaranteed by spring in the body neck.

4) EXTENDED NECK

Extended neck allows for insulation from piping, and is easily accessible for mounting of actuators.

5) DISC DESIGN

The high strength casting discs are as single - piece, the sealing edges are spherically machined, and then hand polished to provide 360° concentric seating bidirectional bubble-tight shut off, minimum torque and longer seat life. The symmetrical disc profile enhances valve performance by increasing the Kv/Cv values, reducing turbulence and increasing pressure recovery.

6) BI-DIRECTIONAL SEALING

The bi-directional, absolutely tight sealing, allows for flexible installation in piping.

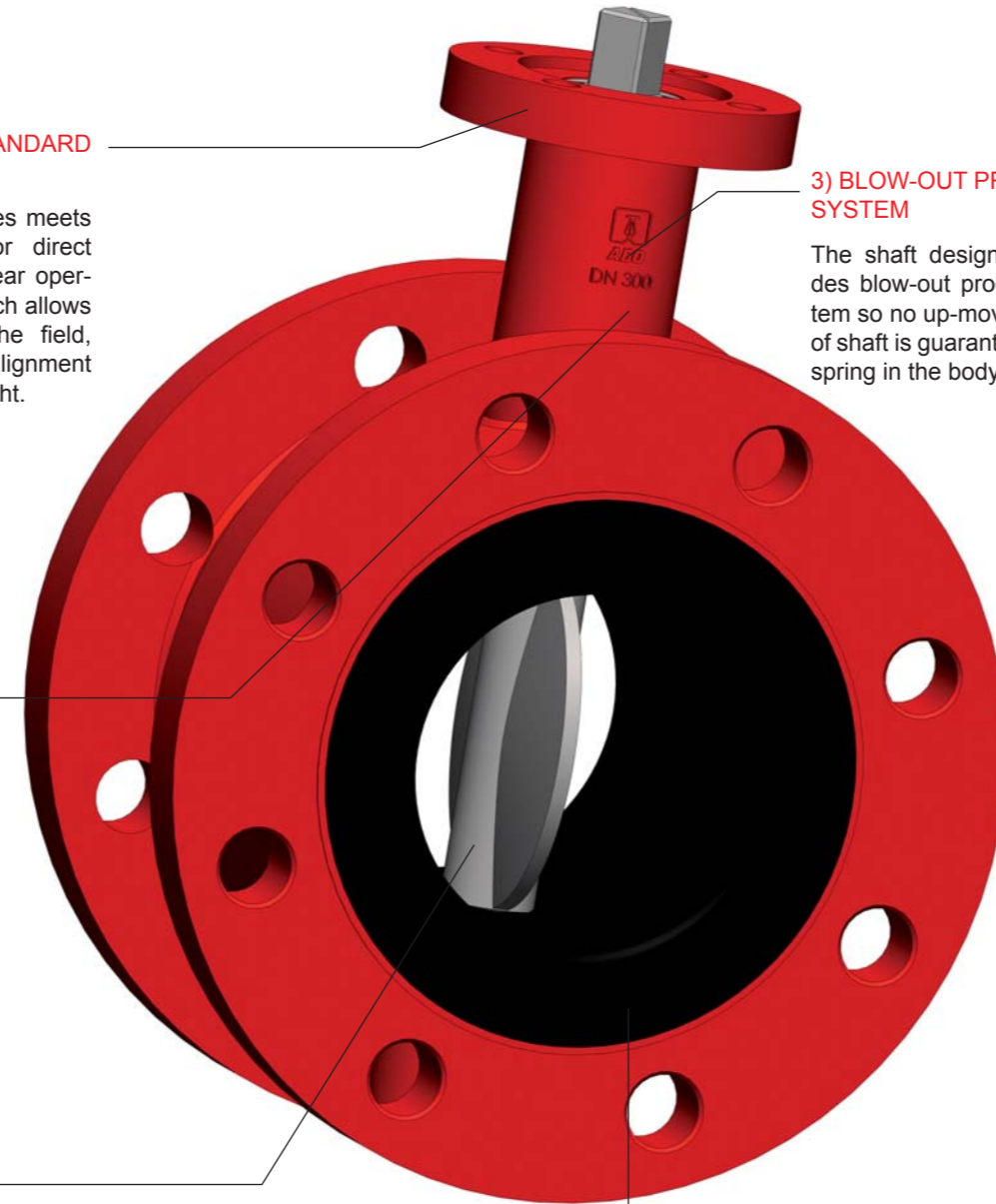

ACTUATION, TORQUES, COATING

ACTUATION POSSIBILITIES

All ABO handles, manual gear operators, pneumatic and electric actuators can be mounted directly to ABO butterfly valves, thus eliminating brackets or couplings. This allows for simple installation in the field, minimizes possible misalignment and decreases overall height.

MANUAL ACTUATION: HANDLEVER

For manual actuation, ABO offers levers in carbon steel material with protective coating for excellent corrosion, abrasion and impact resistance. A lever in stainless steel material is an option. ISO top flange connection is F05 for sizes DN 50 and 65, and F07 for sizes DN 80-200, respectively.

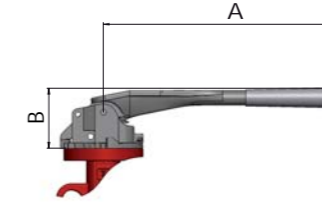

DN	50 - 100	125	150 - 200	250	300
A	270	270	362	450	750
B	75	80	90	135	135
Weight	1,24	1,24	1,40	2,20	3,10

Dimensions mentioned in mm, weight in kg.

MANUAL GEARBOX WITH HANDWHEEL

ABO gearbox series of manual actuators provide a smooth and trouble-free operation for heavy duty on-off and throttling service of ABO valves. The rugged, cast iron body seals are weatherproof to IP65. A self-locking gearing holds the valve in the desired position. Further features include a readily accessible handwheel, adjustable stopcrew for closed position, removable splined drive bush with indexing facility and a facility to lock handwheel with padlock and chain. Gearboxes, as well as handlevers, can be supplemented with contacts for signalization of endpoints.

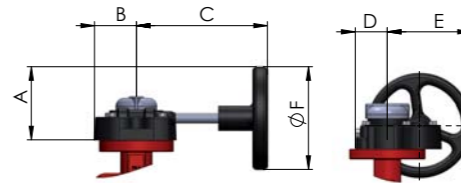

DN	50 - 125	150 - 200	250 - 300	350	400	450	500	600
A	89	155	155	225	275	275	275	350
B	51	66	66	99	99	126	126	157,5
C	152	252	252	245	285	337	337	382
D	44	59	59	96	96	117,5	117,5	145
E	101	177	177	264,5	314,5	348	348	454
F	125	250	250	350	450	450	450	600
Gearbox	SE07	SE10	SE10	M14	M14	M15	M15	M16
Weight	1,6	3,7	3,7	6,6	6,6	14,5	14,5	27,2

Dimensions mentioned in mm, weight in kg.

ACTUATORS

- PNEUMATIC ACTUATORS - ABO pneumatic actuators Series 95 are rack and pinion, opposed-piston actuators available in two versions: single acting & double acting
- ELECTRIC ACTUATORS - ABO series 97 electric actuators are designated for quarter turn operating application. Electric actuators of 24V, 230V and 400V can be installed on ABO butterfly valves.

OPERATING TORQUES UPON WORKING PRESSURE (NM)

PN / DN	mm	50	65	80	100	125	150	200	250	300	350	400	450	500	600
		inch	2"	2 1/2"	3"	4"	5"	6"	8"	10"	12"	14"	16"	18"	20"
PMA 10 bar (145 psi)	wet	13,9	15,4	21,7	37,1	57,9	93,9	173	286	429	550	755	1 012	1 350	2 111
	dry	22,1	29,2	41,1	67,8	101,0	165,0	297	486	699	825	1 133	1 518	2 025	3 166
PMA 16 bar (232 psi)	wet	15,1	17,2	23,1	39,8	61,9	102,0	192	323	490	625	846	1 131	1 431	2 301
	dry	24,2	32,7	43,7	72,8	108,0	174,0	330	549	799	959	1 307	1 787	2 288	3 711

1. Torque in the above table is corresponding to all friction while disc is close and open under normal use. It does not include a safety factor.
2. Normal use means clean medium, temperature of -4.5°C to 93°C, no precipitation in the valve or chemical attack, operating at least once every day.
3. Torque in the table is without considering dynamic torque factor.
4. Must consider safety coefficient for actuators selection.
5. The above mentioned torques are valid for valves with EPDM seat only. While actuating the valve, the above mentioned figures should be multiplied by a coefficient of 1.2. Using a NBR seat, it is necessary to apply a coefficient of 1.25.
6. If the working conditions are specific, it is recommended to discuss the selection of the actuator with the manufacturer.

COATING

Surface Coating: As standard body coating, Fusion Bonded Epoxy coating is applied for excellent corrosion resistance. ABO epoxy coating is executed in orange finish RAL 2002 - 80 µm.

DRAWING, MATERIALS, DIMENSIONS 50 - 300 (2" - 12"), PN 10/16

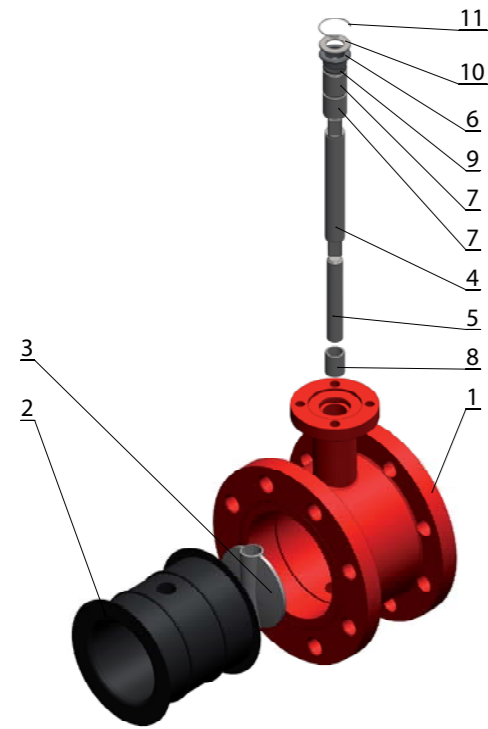

Item	Name	Material
1	Body	Ductile iron 0.7040 (GGG40)
2	Seat	1 - NBR vulcanized 2 - EPDM vulcanized
3	Disc	Ductile iron 0.7040 (GGG40) Stainless steel 1.4308 (CF8) Stainless steel 1.4408 (CF8M)
4	Shaft	Stainless steel 1.4021 (AISI 420)
5	Pivot	Stainless steel 1.4021 (AISI 420)
6	Bushing	Stainless steel 1.4021 (AISI 420)
7	Sleeve 2	PTFE
8	Sleeve 1	PTFE
9	O-ring	NBR / EPDM - depending on seat material
10	Circlip for hole	Stainless steel
11	Clamp Spring	Stainless steel

Execution in other material types can be provided upon request. Choice of the seat and disc materials for various media will be recommended upon specific enquiry. Max. temperatures for each material of seat are accepted only for a specific medium and short time exposure. Please always consult material selection with the manufacturer.

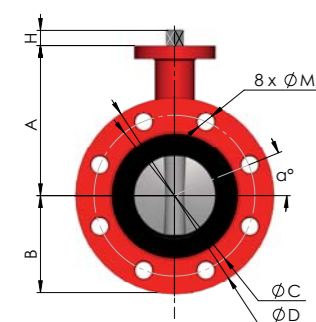

DN		A	B	H	E	ØD	h	ØK	ISO5211	n-ØN
mm	inch									
50	2"	131	84,0	25	14	55	3	90	70	4-Ø7
65	2 1/2"	142	85,0	25	14	55	3	90	70	4-Ø7
80	3"	155	92,5	25	14	55	3	90	70	4-Ø7
100	4"	168	108,5	25	14	55	3	90	70	4-Ø7
125	5"	184	121,5	25	17	55	3	90	70	4-Ø9
150	6"	202	138,0	25	17	55	3	90	70	4-Ø9
200	8"	241	161,5	25	22	70	3	125	102	3-Ø10,5; 1-M10
250	10"	272	195,0	30	22	70	3	125	102	3-Ø10,5; 1-M10
300	12"	308	222,0	30	22	70	3	140	102	4-Ø10,5

DN		L	ØC		ØD		N-ØM		a°	
mm	inch		PN 10	PN 16	PN 10	PN 16	PN 10	PN 16	PN 10	PN 16
50	2"	108	125	125	165	165	4-Ø19	4-Ø19	45,0	45,0
65	2 1/2"	112	145	145	185	185	4-Ø19	4-Ø19	45,0	45,0
80	3"	114	160	160	200	200	4-Ø19	4-Ø19	22,5	22,5
100	4"	127	180	180	220	220	4-Ø19	4-Ø19	22,5	22,5
125	5"	140	210	210	250	250	4-Ø19	4-Ø19	22,5	22,5
150	6"	140	240	240	285	285	4-Ø23	4-Ø23	22,5	22,5
200	8"	152	295	295	340	340	4-Ø23	4-Ø23	22,5	22,5
250	10"	165	350	355	395	405	4-Ø23	4-Ø28	15,0	15,0
300	12"	178	400	410	445	460	4-Ø28	4-Ø28	15,0	15,0

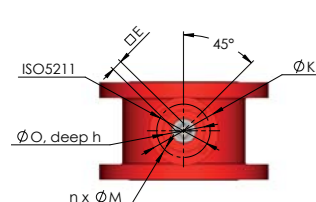

DRAWING, MATERIALS, DIMENSIONS DN 400 - 600 (16" - 24"), PN 10/16

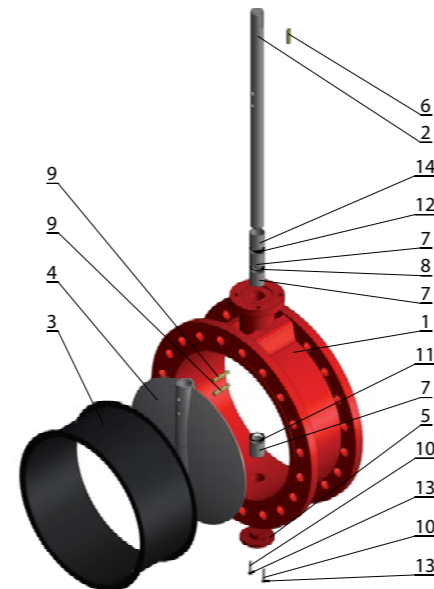

Item	Name	Material
1	Body	Ductile iron 0.7040 (GGG40)
2	Shaft	Stainless steel 1.4401 (AISI 316)
3	Seat	1 - NBR vulcanized 2 - EPDM vulcanized
4	Disc	Ductile iron 0.7040 (GGG40)
5	Lower Cover	Ductile iron 0.7040 (GGG40)
6	Key	Stainless steel
7	Bushing	Bronze
8	O-ring	NBR / EPDM - depending on seat material
9	Pin	Stainless steel 1.4401 (AISI 316)
10	Bolt	Zinc coated steel / Stainless steel
11	O-ring	NBR / EPDM - depending on seat material
12	O-ring	NBR / EPDM - depending on seat material
13	Washer	Zinc coated steel / Stainless steel
14	Bushing	Bronze

Execution in other material types can be provided upon request. Choice of the seat and disc materials for various media will be recommended upon specific enquiry. Max. temperatures for each material of seat are accepted only for a specific medium and short time exposure. Please always consult material selection with the manufacturer.

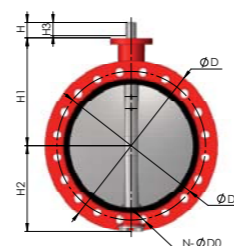

DN		ØD		N-ØM		H	H1	H2	H3	ØE	
mm	inch	PN 10	PN 16	PN 10	PN 16						
400	16"	580	515	525	16-Ø28	16-Ø31	52	375	292	45	33,15
450	18"	640	565	585	20-Ø28	20-Ø31	52	405	307	45	38,00
500	20"	715	620	650	20-Ø28	20-Ø34	64	450	342	55	41,15
600	24"	840	725	770	20-Ø31	20-Ø37	70	518	433	65	50,65

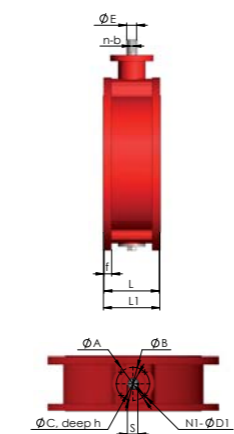

DN		n-b	ØA	ØB	h	ØC	N1-Ød1	L	L1	f	S
mm	inch										
400	16"	1.10	175	140	4	100	4-Ø18	216	221	28,0	36,15
450	18"	1.10	175	140	4	100	4-Ø18	222	227	30,0	41,00
500	20"	1.12	175	140	4	100	4-Ø18	229	234	31,5	44,15
600	24"	2.16	210	165	5	130	4-Ø22	267	272	36,0	54,65

Weight mentioned in kg.

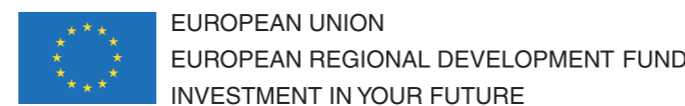

All statements, technical information in this brochure are tentative and for general use only and do not constitute a recommendation or guarantee for any specific service or application requirement. Consult ABO representative or factory for specific requirements and material selection for your intended application. The right to change or modify product design or product without prior notice is reserved. Binding specification will be provided in each offer. ABO valve accepts no liability for damages caused by bad interpretation or use of the information included in this brochure.

30.11.2014

Data subject to change.

- Company HQ - Czech Republic:** ABO valve, s.r.o. Dalimilova 285/54, 783 35 Olomouc Tel: +420 585 202 226, +420 585 224 087 Email: export@abovalve.com www.abovalve.com
- Slovakia:** ABO Slovakia, s.r.o. Banská Bystrica Tel: +421 484 145 633 Email: aboslovakia@aboslovakia.sk www.aboslovakia.sk
- Russia:** ABO ARMATURA Ltd. Smolensk Tel: +7 4812 31 28 27 Email: aboarmatura@yandex.ru www.aboarmatura.ru
- Singapore:** ABO Valve Pte. Ltd. Singapore Tel: +65 6383 4368 Email: lsw@abovalve.com www.abovalve.com
- China:** ABO Flow Control Shanghai Tel: +86 136 015 228 31 Email: wen@abovalve.com www.abovalve.com
- Bahrain:** ABO Middle East Kingdom of Bahrain Tel: +973 3444 9065 Email: jimnich@abovalve.com www.abovalve.com

ABO valve ABSolute flow control

SERIES 900L

- // PN 10/16/Class 150
- // DN 50 - 600 (2" - 24")
- // Water and Wastewater
- // Potable Water
- // Food and Beverage



DOUBLE FLANGED BUTTERFLY VALVES