

HEGTOLDATOS ACÉLKARIMA

Welding neck

EN 1092-1 type 11

PN250

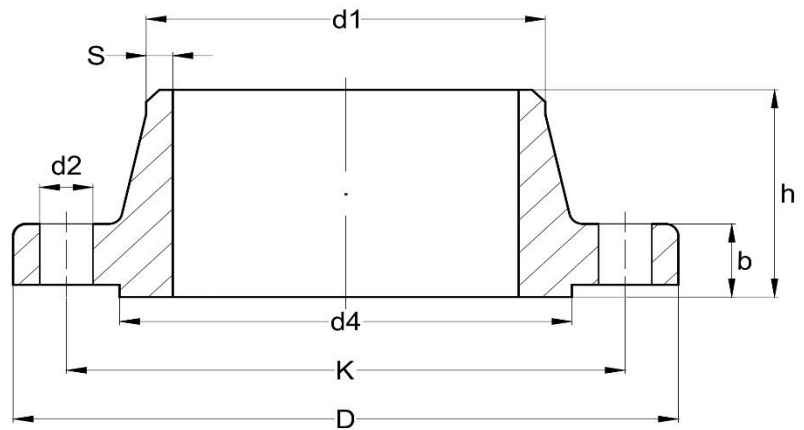

DN	D	k	d2	n	Csavar méret	d1	b	h	d4	s	súly (kg)
15	130	90	18	4	M16	21,3	26	60	45	2,6	2,51
25	150	105	22	4	M20	33,7	28	65	68	3,6	3,58
40	185	135	26	4	M24	48,3	34	80	88	5	6,72
50	200	150	26	8	M24	60,3	38	85	102	6,3	8,22
65	230	180	26	8	M24	76,1	42	95	122	8	12,8
80	255	200	30	8	M27	101,6	46	102	138	11	16,5
100	300	235	33	8	M30	127	54	120	162	14,2	27,2
125	340	275	33	12	M30	152,4	60	140	188	16	39
150	390	320	36	12	M33	177,8	68	160	218	17,5	59,6
200	485	400	42	12	M39	244,5	82	190	285	25	110
250	585	490	48	16	M45	298,5	100	215	345	32	190

