

HEGTOLDATOS ACÉLKARIMA

Welding neck

EN 1092-1 type 11

PN63

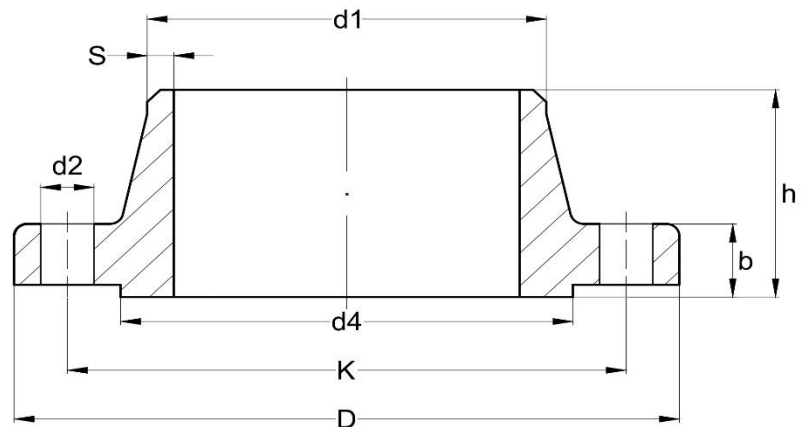

DN	D	k	d2	n	Csavar méret	d1	b	h	d4	s	súly (kg)
10	100	70	14	4	M12	17,2	20	45	40	2	1,09
15	105	75	14	4	M12	21,3	20	45	45	3,2	1,2
20	130	90	18	4	M16	26,9	22	48	58	3,2	2,02
25	140	100	18	4	M16	33,7	24	58	68	3,6	2,63
32	155	110	22	4	M20	42,4	24	60	78	3,6	3,2
40	170	125	22	4	M20	48,3	26	62	88	3,6	4,07
50	195	145	26	4	M24	60,3	28	68	102	4	5,82
65	220	170	26	8	M24	76,1	30	76	122	4	7,57
80	230	180	26	8	M24	88,9	32	78	138	5	8,82
100	265	210	30	8	M27	114,3	36	90	162	5,6	13,1
125	315	250	33	8	M30	139,7	40	105	188	6,3	21
150	355	290	33	12	M30	168,3	44	115	218	8	28,3
200	430	360	36	12	M33	219,1	52	130	285	8,8	50,2
250	505	430	39	12	M36	273	60	157	345	10	81,4
300	585	500	42	16	M39	323,9	68	170	410	12,5	118
350	655	560	48	16	M45	355,6	74	189	465	14,2	169

