

HEGTOLDATOS ACÉLKARIMA

Welding neck

EN 1092-1 type 11

PN10

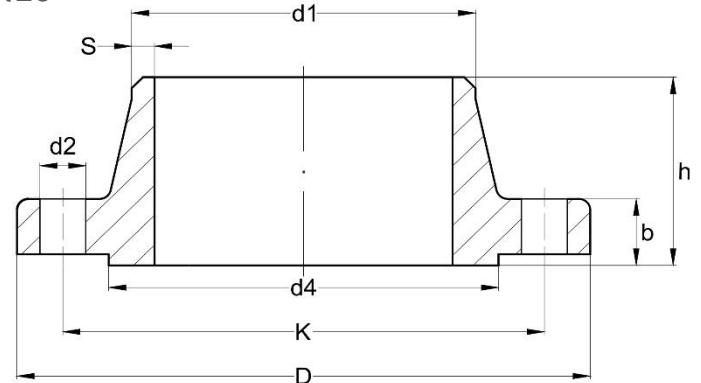

DN	D	k	d2	n	Csavar méret	d1	b	h	d4	s	súly (kg)
10-40	DN 10-től DN 40-ig azonos a PN40 hegtoldatos karimával										
50-150	DN 50-től DN 150-ig azonos a PN16 hegtoldatos karimával										
200	340	295	22	8	M20	219,1	24	62	268	6,3	11,6
250	395	350	22	12	M20	273	26	68	320	6,3	15,8
300	445	400	22	12	M20	323,9	26	68	370	7,1	18,3
350	505	460	22	16	M20	355,6	26	68	430	7,1	25,3
400	565	515	26	16	M24	406,4	26	72	482	7,1	30,6
450	615	565	26	20	M24	457	28	72	532	7,1	35,1
500	670	620	26	20	M24	508	28	75	585	7,1	40,5
600	780	725	30	20	M27	610	30	82	685	8	52,9
700	895	840	30	24	M27	711	35	85	800	8,8	75,8
800	1015	950	33	24	M30	813	38	96	905	8,8	102
900	1115	1050	33	28	M30	914	38	99	1005	12,5	121
1000	1230	1160	36	28	M33	1016	44	105	1110	12,5	161
1200	1455	1380	39	32	M36	1219	55	132	1330	12,5	258
1400	1675	1590	42	36	M39	1422	65	143	1535	14,2	371
1600	1915	1820	48	40	M45	1626	75	159	1760	16	547
1800	2115	2020	48	44	M45	1829	85	175	1960	17,5	691
2000	2325	2230	48	48	M45	2032	90	186	2170	17,5	830
2200	2550	2440	56	52	M52	2235	100	202	2370	20	1073
2400	2760	2650	56	56	M52	2438	110	218	2570	22,2	1329
2600	2960	2850	56	60	M52	2620	110	224	2780	25	1574
2800	3180	3070	56	64	M52	2820	124	244	3000	25	1987
3000	3405	3290	62	68	M56	3020	132	257	3210	32	2476

