

STAINLESS STEEL BALL PIVOT MONTHAHN

DN 65-150 PN 40

3.258.

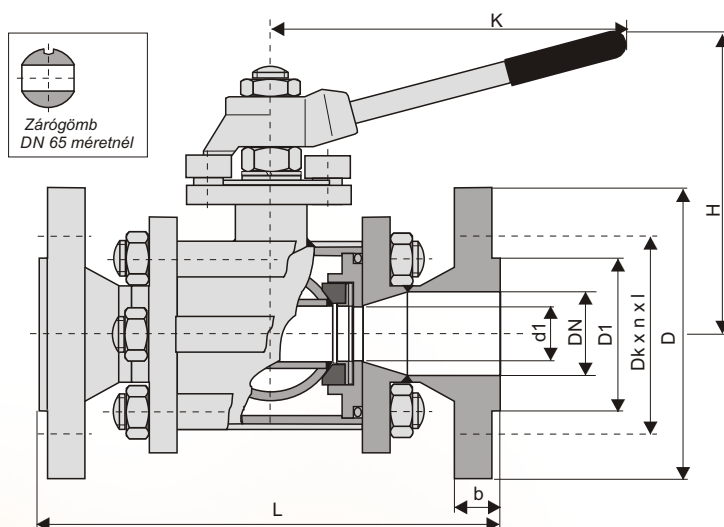

vtsz.8481808100

JOINING SIZE:

DIN 2501 (flanged)

GRADE OF SEEPAGE:

MSZ 4563-1983. 3.1.

DIN 3230/3 BO 1.

CONSTRUCTION OF LENGTH:

DIN 3201-F1 (flanged)

DIN 3202-S8 (welded)

AREA OF APPLICATION:

For cold and hot water, for steam, for acids and alkalis, for liquids iner to the material of the parts in the following range shown in the operational pressure-temperature diagram

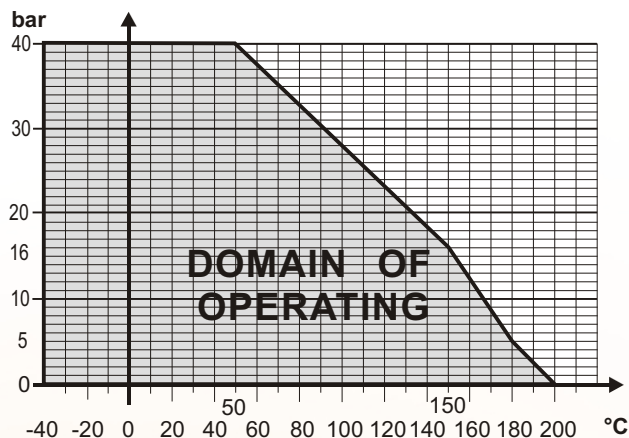

DN	d1	D1	Dk x n x l	D	L	b	H	K	kg/db
65	50	122	145 x 8 x 18	185	270	22	185	300	13
80	65	138	160 x 8 x 18	200	280	24	219	400	18
100	80	162	190 x 8 x 23	235	300	24	252	500	26
125	95	188	220 x 8 x 27	270	325	26	313	750	38
150	120	218	250 x 8 x 27	300	350	28	380	950	44

MATERIALS OF MAIN PARTS:

Specifying	Material quality (~)
Case	1.4541 MSZ EN 10088-1
Ball	1.4541 MSZ EN 10088-1
Seat	PTFE + 25% Cg
Shaft	1.4462 MSZ EN 10088-1
Shaft sealing	2 db PTFE ring 1 db FPM "O" ring

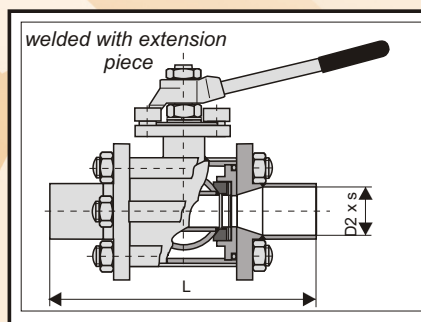

DN	D2 x S	L	kg/db
65	76,1 x 2,9	270	7
80	88,9 x 3,2	280	9
100	108 x 3,6	300	17
125	133 x 4	325	32
150	159 x 4,5	350	39

TORQUE:

