

SAVÁLLÓ BB MENETES GOLYÓSCSAP

két részes, könnyített NKB211

2-PC Light Duty Ball Valve



Méret	1/4"	3/8"	1/2"	3/4"	1"	1 1/4"	1 1/2"	2"	2 1/2"	3"
d	11,6	12,5	15	20	25	32	38	50	64	76
L	48,5	48,5	56,5	65	77	87	98	117,5	145	167,5
H	48	48	52,5	59,5	64,5	75	80	93	130	138
W	91	91	100	113	113	143	143	165	230	230

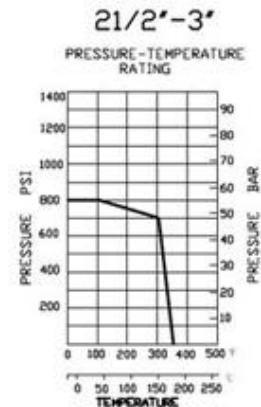
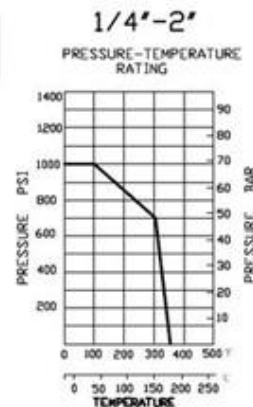
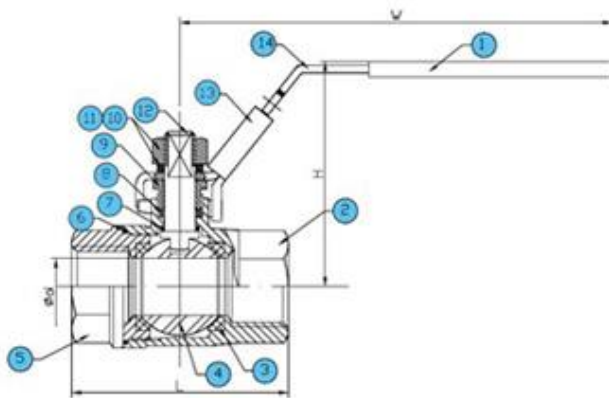

1	HANDLE COVER	PLASTIC
2	BODY	CF8/CF8M
3	BALL SEAT	PTFE
4	BALL	CF8/CF8M
5	CAP	CF8/CF8M
6	JOINT GASKET	PTFE
7	THRUST WASHER	PTFE
8	STEM PACKING	PTFE
9	GLAND NUT	SUS304
10	SPRING WASHER	SUS304
11	STEM NUT	SUS304
12	STEM	SUS304/316
13	LOCK DEVICE	SUS304
14	HANDLE	SUS304

1000PSI/PN63

Full Port

Investment Casting

Blow-out Proof Stem

Locking Device Handle(Optional)

PED97/23/EC(CE 0035) Approved

Casting Approved AD2000-W0

Thread: ASME B1.20.1 BS21.DIN2999/259,

ISO228-1, JIS B 0203,ISO7/1

Inspection Testing: API598, EN12266

